

19



Europäisches Patentamt
European Patent Office
Office européen des brevets

11

Publication number:

0 063 879
A2

12

EUROPEAN PATENT APPLICATION

21

Application number: 82301804.9

51

Int. Cl.: C 07 H 19/20, C 07 H 19/10,
C 07 H 19/14, C 07 H 21/00,
G 01 N 33/48

22

Date of filing: 06.04.82

30

Priority: 17.04.81 US 255223

71

Applicant: YALE UNIVERSITY, Woodbridge Hall
Box 1302A Yale Station, New Haven, CT 06520 (US)

43

Date of publication of application: 03.11.82
Bulletin 82/44

72

Inventor: Ward, David C., 40 Peddlers Road, Guilford
Connecticut 06437 (US)
Inventor: Waldrop, Alexander A., III, 2663 D Hydraulic
Road, Charlottesville Virginia 22901 (US)
Inventor: Langer, Pennina R., 57 College Road, Monsey
New York 10952 (US)

84

Designated Contracting States: AT BE CH DE FR GB IT
LI LU NL SE

74

Representative: Logen, Allan Beattle, 33, Audley Road,
Ealing London W5 3ES (GB)

54

Modified nucleotides and methods of preparing and using same.

57

Compounds having the structure:

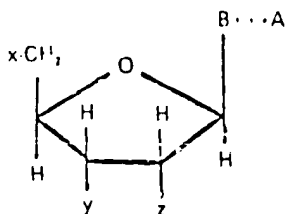

deazapurine, the linkage is attached to the 7-position of the deazapurine, and if B is pyrimidine, the linkage is attached to the 5-position of the pyrimidine; and wherein each of x, y and z represents

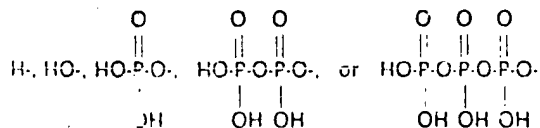

wherein B represents a purine, 7-deazapurine, or pyrimidine moiety covalently bonded to the C1'-position of the sugar moiety, provided that when B is purine or 7-deazapurine, it is attached at the N⁹-position of the purine or 7-deazapurine and when B is pyrimidine, it is attached at the N¹-position;

wherein A represents a moiety consisting of at least three carbon atoms which is capable of forming a detectable complex with a polypeptide when the compound is incorporated into a double-stranded ribonucleic acid, deoxyribonucleic acid duplex, or DNA-RNA hybrid; wherein the dotted line represents a chemical linkage joining B and A, provided that if B is purine, the linkage is attached to the 8-position of the purine, if B is 7-

either directly, or when incorporated into oligo- and polynucleotides, provide probes which are widely useful.

Applications include detection and localization of polynucleotide sequences in chromosomes, fixed cells, tissue sections, and cell extracts. Specific applications include chromosomal karyotyping, clinical diagnosis of nucleic acid-containing etiological agents, e.g. bacteria, viruses, or fungi, and diagnosis of genetic disorders.

EP 0 063 879 A2

MODIFIED NUCLEOTIDES AND
METHODS OF PREPARING AND USING SAME

BACKGROUND OF THE INVENTION

5 Many procedures employed in biomedical research and recombinant DNA technology rely heavily on the use of nucleotide or polynucleotide derivatives radioactively labeled with isotopes of hydrogen (^3H), phosphorous (^{32}P), carbon (^{14}C), or iodine (^{125}I). Such radioactive compounds provide useful indicator probes that permit the user to detect, monitor, localize, or isolate nucleic acids and other molecules of scientific or clinical interest, even when present in only extremely small amounts. To date, radioactive materials have provided the most sensitive, and in many cases the only, means to perform many important experimental or analytical tests. There are, however, serious limitations and drawbacks associated with the use of radioactive compounds. First, since personnel who handle radioactive material can be exposed to potentially hazardous levels of radiation, elaborate safety precautions must be maintained during the preparation, utilization, and disposal of the radioisotopes. Secondly, radioactive nucleotides are extremely expensive to purchase and use, in large part due to the cost of equipment and manpower necessary to provide the appropriate safeguards, producer/user health monitoring services, and waste-disposal programs. Thirdly, radioactive materials are often very unstable and have a limited shelf-life, which further increases usage costs. This instability results from radiolytic decomposition, due to the destructive effects associated with the decay of the radioisotope itself, and from the fact that many isotopes (e.g. ^{32}P and ^{125}I) have half-lives of only a few days.

35 It is known that haptens can combine with antibodies, but can initiate an immune response only if bound to a carrier. This property can be exploited in detection and identification testing.

It is also known that biotin and iminobiotin strongly interact with avidin, a 68,000 dalton glycoprotein from egg white. This interaction exhibits one of the tightest, non-covalent binding constants ($K_{dis} = 10^{-15}$) seen in nature.

5 If avidin is coupled to potentially demonstrable indicator molecules, including fluorescent dyes, e.g. fluorescein or rhodamine; electron-dense reagents, e.g. ferritin, hemocyanin, or colloidal gold; or enzymes capable of depositing insoluble reaction products, e.g. peroxidase or

10 alkaline phosphatase, the presence, location, or quantity of a biotin probe can be established. Although iminobiotin binds avidin less tightly than biotin, similar reactions can be used for its detection. Moreover, the reversibility of the iminobiotin-avidin interaction, by decreasing solution pH, offers significant advantages in certain

15 applications.

The specificity and tenacity of the biotin-avidin complex has been used in recent years to develop methods for

20 visually localizing specific proteins, lipids, or carbohydrates on or within cells (reviewed by E.A. Bayer and M. Wilchek in *Methods of Biochemical Analysis*, 26, 1, 1980). Chromosomal location of RNA has been determined by electron microscopy using a biotinized protein, cytochrome

25 C, chemically cross-linked to RNA as a hybridization probe. The site of hybridization was visualized through the binding of avidin-ferritin or avidin-methacrylate spheres mediated by the avidin-biotin interaction (J.E. Manning, N.D. Hershey, T.R. Broker, M. Pellegrini, H.K. Mitchell, and N. Davidson, *Chromosoma*, 53, 107, 1975; J.E. Manning, M. Pellegrini, and N. Davidson, *Biochemistry*, 61, 1364, 1977; T.R. Broker, L.M. Angerer, P.H. Yen, N.D. Hershey, and N. Davidson, *Nucleic Acid Res.*, 5, 363, 1978; A. Sodja and N. Davidson, *Nucleic Acid Res.*, 5, 383, 1978). This approach

35 to the detection of polynucleotide sequences, although successful in the specialized cases examined which were highly reiterated sequences, is not of general utility for analysis

of polynucleotides present in single or low copy number.

Moreover, methods for attaching chemical moieties to pyri-
5 midine and purine rings are known. Several years ago a
simple and rapid acetoxymercuration reaction was develop-
ed for introducing covalently bound mercury atoms into the
5-position of the pyrimidine ring, the C-8 position of the
purine ring or the C-7 position of a 7-deazapurine ring,
10 both in nucleotides and polynucleotides. (R.M.K. Dale,
D.C. Livingston and D.C. Ward, Proc. Natl. Acad. Sci.
U.S.A., 70, 2238, 1973; R.M.K. Dale, E. Martin, D.C. Livin-
gston and D.C. Ward, Biochemistry, 14, 2447, 1975.) It
was also shown several years ago that organomercurial com-
15 pounds would react with olefinic compounds in the prese-
nce of palladium catalysts to form carbon-carbon bonds
(R.F. Heck, J. Am. Chem. Soc., 90, 5518, 1968; R.F. Heck,
Ibid., 90 5526, 1968; R.F. Heck, Ibid., 90, 5531, 1968;
R.F. Heck, Ibid., 90, 5535, 1968; and R.F. Heck, J. Am.
20 Chem.Soc. 91, 6707, 1969.) Bergstrom and associates
(J.L. Ruth and D.E. Bergstrom, J. Org. Chem., 43, 2870,
1978; and D.E. Bergstrom and M.K. Ogawa, J. Am. Chem.
Soc., 100, 8106, 1978) and Bigge, et al. (C.F. Bigge,
P. Kalaritis, J.R. Deck and M.P. Mertes J. Am. Chem. Soc.,
25 102 2033, 1980) have recently applied this reaction scheme
in the synthesis of C-5 substituted pyrimidine nucleotide
compounds.

30

Finally, it is known that antibodies specific for modified
nucleotides can be prepared and used for isolating and cha-
racterizing specific constituents of the modified nucleo-
tides. (T.W. Munns and M.K. Liszewski, Progress in Nucleic
35 Acid Research and Molecular Biology, 24, 109, 1980.) How-
ever, none of the antibodies prepared to date against na-
turally occurring nucleotides have been shown to react with

their nucleotide determinant when it exists in a double-stranded RNA or DNA duplex or when in DNA-RNA hybrid molecules.

5 To circumvent the limitations of radioactively labeled probes or previously utilized chemical and biological probes, a series of novel nucleotide derivatives that contain biotin, iminobiotin, lipoic acid, and other determinants attached covalently to the pyrimidine or purine ring
10 have been synthesized. These nucleotide derivatives, as well as polynucleotides and coenzymes that contain them, will interact specifically and uniquely with proteins such as avidin or antibodies. The interaction between modified nucleotides and specific proteins can be utilized as an alternative to radioisotopes for the detection and localization of nucleic acid components in many of the procedures currently used in biomedical and recombinant-DNA technologies. Methods employing these modified nucleotide-protein interactions have detection capacities equal to or greater
15 than procedures which utilize radioisotopes and they often can be performed more rapidly and with greater resolving power.

These new nucleotide derivatives can be prepared relatively
25 inexpensively by chemical procedures which have been developed and standardized as discussed more fully hereinafter. More significantly, since neither the nucleotide probes of this invention nor the protein reagents employed with them are radioactive, the compounds can be prepared, utilized, and disposed of, without the elaborate safety
30 procedures required for radioisotopic protocols. Moreover, these nucleotide derivatives are chemically stable and can be expected to have functional shelf-lives of several years or more. Finally, these compounds permit the development
35 of safer, more economical, more rapid, and more reproducible research and diagnostic procedures.

SUMMARY OF THE INVENTION

Compounds having the structure:

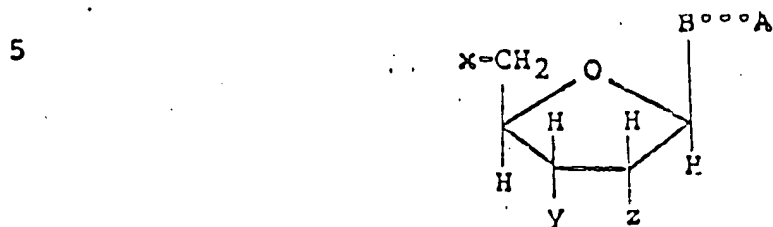

10 wherein B represents a purine, deazapurine, or pyrimidine moiety covalently bonded to the C^{1'}-position of the sugar moiety, provided that when B is purine or 7-deazapurine, it is attached at the N⁹-position of the purine or deazapurine, and when B is pyrimidine, it is attached at the
15 N¹-position;

wherein A represents a moiety consisting of at least three carbon atoms which is capable of forming a detectable complex with a polypeptide when the compound is incorporated
20 into a double-stranded ribonucleic acid, deoxyribonucleic acid duplex, or DNA-RNA hybrid;

wherein the dotted line represents chemical linkage joining B and A, provided that if B is purine the linkage is
25 attached to the 8-position of the purine, if B is 7-deazapurine, the linkage is attached to the 7-position of the deazapurine, and if B is pyrimidine, the linkage is attached to the 5-position of the pyrimidine; and

30 wherein each of x, y, and z represents

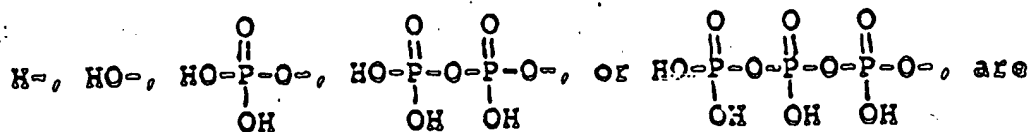

35 widely useful as probes in biomedical research and recombinant DNA technology.

Particularly useful are compounds encompassed within this structure which additionally have one or more of the following characteristics: A is non-aromatic; A is at least C₅; the chemical linkage joining B and A includes an α-olefinic bond; A is biotin or iminobiotin; and B is a pyrimidine or 7-deazapurine.

These compounds may be prepared by a process which involves:

10

(a) reacting a compound having the structure:

15

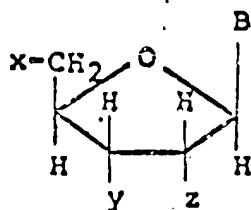

with a mercuric salt in a suitable solvent under suitable conditions so as to form a mercurated compound having the structure:

20

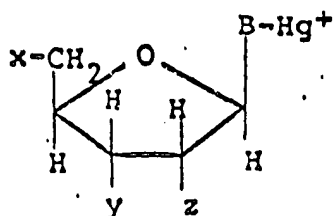

25

(b) reacting said mercurated compound with a chemical moiety reactive with the -Hg⁺ portion of said mercurated compound and represented by the formula ...N, said reaction being carried out in an aqueous solvent and in the presence of K₂PdCl₄ under suitable conditions so as to form a compound having the structure:

30

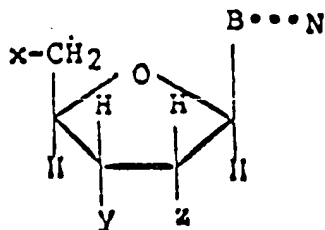

35

wherein N is a reactive terminal functional group or is A; and

(c) recovering said compound as said modified nucleotide when N is A, or when N is a reactive terminal group, reacting said compound with a compound having the structure M-A, wherein M represents a functional group reactive with N in an aqueous solvent under suitable conditions so as to form said modified nucleotide, which is then recovered.

This invention also provides compounds having the structure:

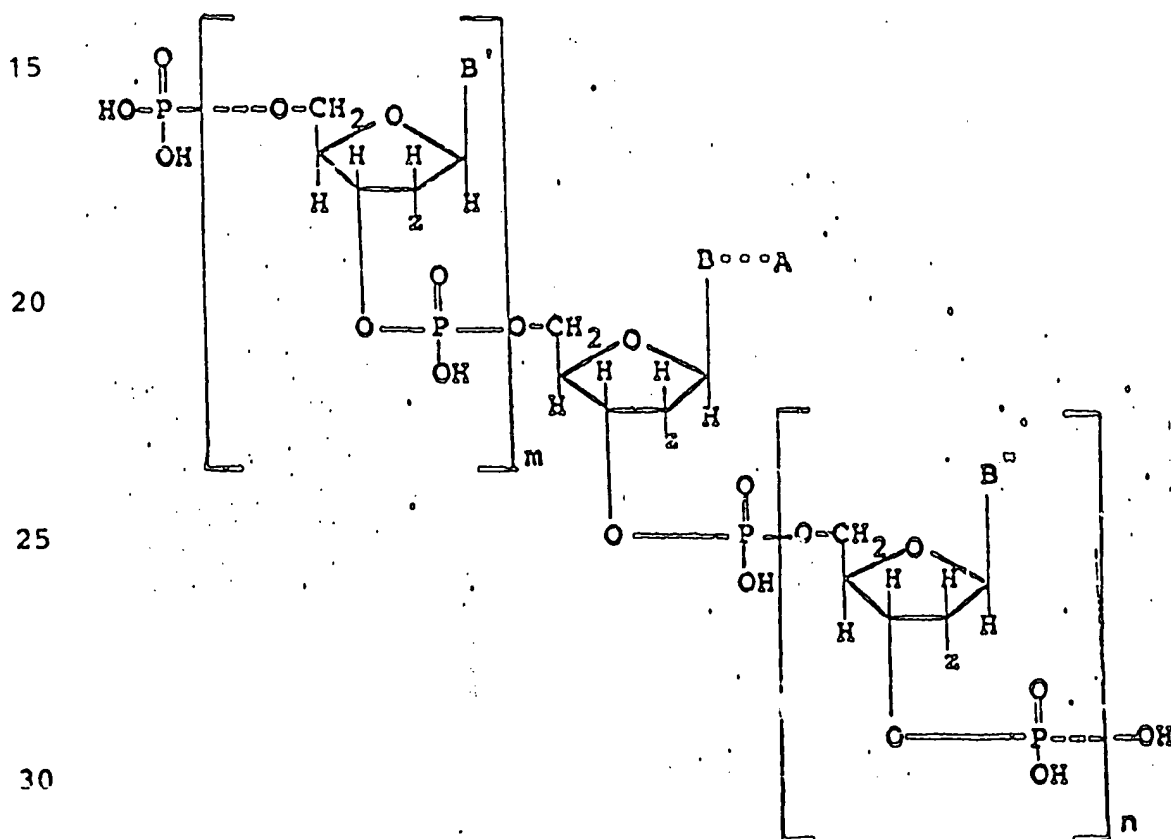

wherein each of B, B', and B'' represents a purine, 7-deazapurine, or pyrimidine moiety covalently bonded to the C^{1'}-position of the sugar moiety, provided that whenever B, B', or B'' is purine or 7-d azapurine, it is attached at the N⁹-position of the purine or 7-deazapurine, and

whenever B, B', or B'' is pyrimidine, it is attached at the N¹-position;

wherein A represents a moiety consisting of at least three carbon atoms which is capable of forming a detectable complex with a polypeptide when the compound is incorporated into a double-stranded duplex formed with a complementary ribonucleic or deoxyribonucleic acid molecule.

10 wherein the dotted line represents a chemical linkage joining B and A, provided that if B is purine the linkage is attached to the 8-position of the purine, if B is 7-deazapurine, the linkage is attached to the 7-position of the deazapurine, and if B is pyrimidine, the linkage
15 is attached to the 5-position of the pyrimidine;

wherein z represents H- or HO-; and

wherein m and n represent integers from 0 up to about
20 100,000.

These compounds can be prepared by enzymatic polymerization of a mixture of nucleotides which include the modified nucleotides of this invention. Alternatively, nucleotides
25 present in oligo- or polynucleotides may be modified using chemical methods.

Nucleotides modified in accordance with the practices of this invention and oligo- and polynucleotides into which
30 the modified nucleotides have been incorporated may be used as probes in biomedical research, clinical diagnosis, and recombinant DNA technology. These various utilities are based upon the ability of the molecules to form stable complexes with polypeptides which in turn can be detected,
35 either by means of properties inherent in the polypeptide or by means of detectable moieties which are attached to, or which interact with, the polypeptide.

Some uses include detecting and identifying nucleic acid-containing etiological agents, e.g. bacteria and viruses; screening bacteria for antibiotic resistance; diagnosing genetic disorders, e.g. thalassemia and sickle cell anemia; chromosomal karyotyping; and identifying tumor cells.

DETAILED DESCRIPTION OF THE INVENTION

10

Several essential criteria must be satisfied in order for a modified nucleotide to be generally suitable as a substitute for a radioactively-labeled form of a naturally occurring nucleotide. First, the modified compound must contain a substituent or probe that is unique, i.e., not normally found associated with nucleotides or polynucleotides. Second, the probe must react specifically with chemical or biological reagents to provide a sensitive detection system. Third, the analogs must be relatively efficient substrates for commonly studied nucleic acid enzymes, since numerous practical applications require that the analog be enzymatically metabolized, e.g., the analogs must function as substrates for nucleic acid polymerases. For this purpose, probe moieties should not be placed on ring positions that sterically, or otherwise, interfere with the normal Watson - Crick hydrogen bonding potential of the bases. Otherwise, the substituents will yield compounds that are inactive as polymerase substrates. Substitution at ring positions that alter the normal "anti" nucleoside conformation also must be avoided since such conformational changes usually render nucleotide derivatives unacceptable as polymerase substrates. Normally, such considerations limit substitution positions to the 5-position of a pyrimidine and the 7-position of a purine or a 7-deazapurine.

15

20

25

30

35

Fourth, the detection system should be capable of inter-

acting with probe substituents incorporated into both single-stranded and double-stranded polynucleotides in order to be compatible with nucleic acid hybridization methodologies. To satisfy this criterion, it is preferable that the probe moiety be attached to the purine or pyrimidine through a chemical linkage or "linker arm" so that it can readily interact with antibodies, other detector proteins, or chemical reagents.

Fifth, the physical and biochemical properties of polynucleotides containing small numbers of probe substituents should not be significantly altered so that current procedures using radioactive hybridization probes need not be extensively modified. This criterion must be satisfied whether the probe is introduced by enzymatic or direct chemical means.

Finally, the linkage that attaches the probe moiety should withstand all experimental conditions to which normal nucleotides and polynucleotides are routinely subjected, e.g., extended hybridization times at elevated temperatures, phenol and organic solvent extraction, electrophoresis, etc.

All of these criteria are satisfied by the modified nucleotides described herein.

These modified nucleotides have the structure:

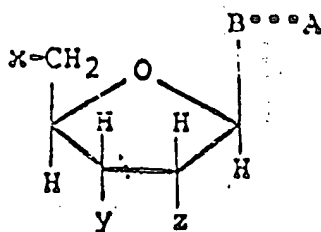

30

wherein B represents a purine, 7-deazapurine, or pyrimidine moiety covalently bonded to the C^{1'}-position of the sugar moiety, provided that when B is purine or 7-deazapurine, it is attached at the N⁹-position of the purine or 7-deaza-

35

purine, and when B is pyrimidine, it is attached at the N¹-position;

wherein A represents a moiety consisting of at least three carbon atoms which is capable of forming a detectable complex with a polypeptide when the compound is incorporated into a double-stranded ribonucleic acid, deoxyribonucleic acid duplex, or DNA-RNA hybrid;

wherein the dotted line represents a linkage group joining B and A, provided that if B is purine the linkage is attached to the 8-position of the purine, if B is 7-deazapurine, the linkage is attached to the 7-position of the deazapurine, and if B is pyrimidine, the linkage is attached to the 5-position of the pyrimidine; and

wherein each of x, y and z represents

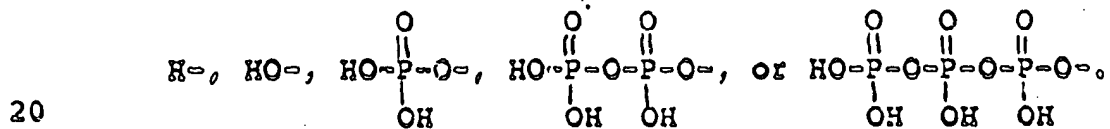

These compounds are widely useful as probes in biomedical research and recombinant DNA technology.

Although in principal all compounds encompassed within this structural formula may be prepared and used in accordance with the practices of this invention, certain of the compounds are more readily prepared or used or both, and therefore are presently preferred.

Thus, although purines, pyrimidines and 7-deazapurines are in principle useful, pyrimidines and 7-deazapurines are preferred since purine substitution at the 8-position tends to render the nucleotides ineffective as polymerase substrates. Thus, although modified purines are useful in certain respects, they are not as generally useful as pyrimidines and 7-deazapurines. Moreover, pyrimidines

and 7-deazapurines useful in this invention must not be naturally substituted at the 5- or 7- positions, respectively. As a result, certain bases such as thymine, 5-methylcytosine, and 5-hydroxymethylcytosine are not useful.

5 Presently preferred bases are cytosine, uracil, deazaadenine and deazaguanine.

A may be any moiety which has at least three carbon atoms and is capable of forming a detectable complex with a polypeptide when the modified nucleotide is incorporated
10 into a double-stranded duplex containing either deoxyribonucleic or ribonucleic acid.

A therefore may be any ligand which possesses these properties, including haptens which are only immunogenic when
15 attached to a suitable carrier, but are capable of interacting with appropriate antibodies to produce complexes.

Examples of moieties which are useful include:

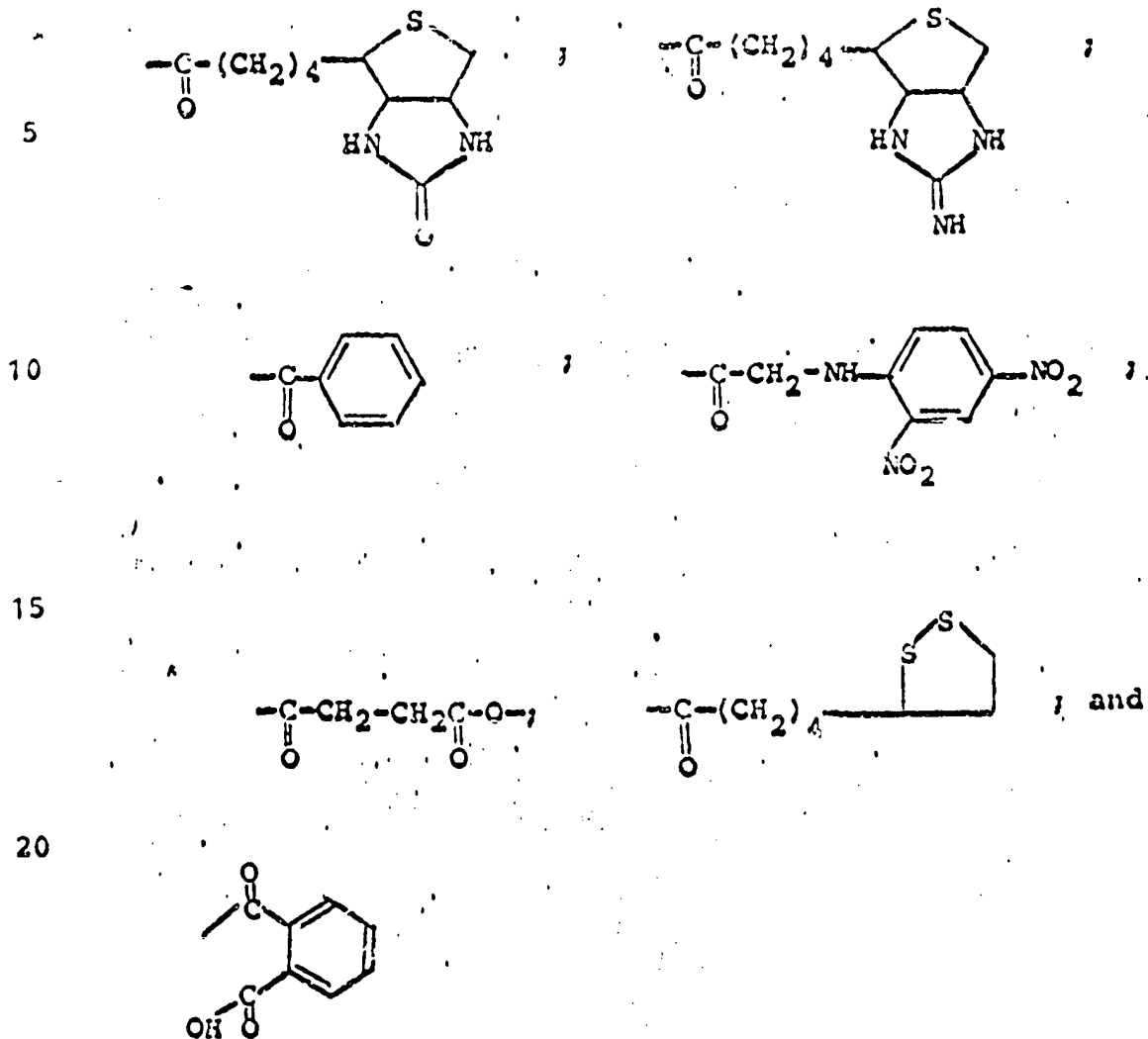

25

Of these the preferred A moieties are biotin and iminobiotin.

Moreover, since aromatic moieties tend to intercalate in-
30 to a base-paired helical structure, it is preferred that the moiety A be non-aromatic. Also, since smaller moieties may not permit sufficient molecular interaction with polypeptides, it is preferred that A be at least C₅ so that sufficient interaction can occur to permit formation of
35 stable complexes. Biotin and iminobiotin satisfy both of these criteria.

The linkage or group joining moiety A to base B may include any of the well known bonds including carbon-carbon single bonds, carbon-carbon double bonds, carbon-nitrogen single bonds, or carbon-oxygen single bonds. However, it is generally preferred that the chemical linkage include an olefinic bond at the α -position relative to B. The presence of such an α -olefinic bond serves to hold the moiety A away from the base when the base is paired with another in the well known double-helix configuration. This permits interaction with polypeptide to occur more readily, thereby facilitating complex formation. Moreover, single bonds with greater rotational freedom may not always hold the moiety sufficiently apart from the helix to permit recognition by and complex formation with polypeptide.

It is even more preferred that the chemical linkage group be derived from a primary amine, and have the structure $-\text{CH}_2\text{-NH-}$, since such linkages are easily formed utilizing any of the well known amine modification reactions. Examples of preferred linkages derived from allylamine and allyl-(3-amino-2-hydroxy-1-propyl) ether groups have the formulae

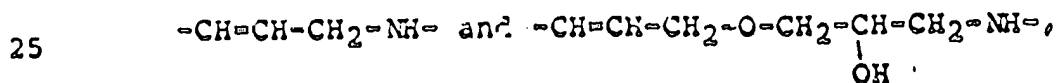

respectively.

Although these linkages are preferred, others can be used, including particularly olefin linkage arms with other modifiable functionalities such as thiol, carboxylic acid, and epoxide functionalities.

The linkage groups are attached at specific positions, namely, the 5-position of a pyrimidine, the 8-position of a purine, or the 7-position of a deazapurine. As indicated previously, substitution at the 8-position of a

purine does not produce a modified nucleotide which is useful in all the methods discussed herein. It may be that the 7-position of a purine, which is occupied by a nitrogen atom, could be the point of linkage attachment.

5 However, the chemical substitution methods employed to date and discussed herein are not suitable for this purpose.

The letters x, y, and z represent groups attached to the 5', 3', and 2' positions of the sugar moiety. They may
10 be any of

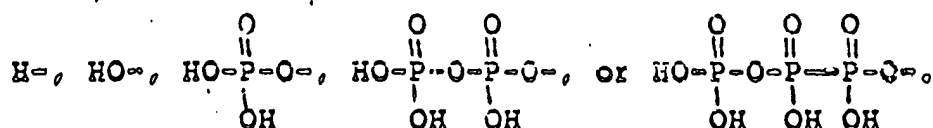

15 Although conceivable, it is unlikely that all of x, y, and z will simultaneously be the same. More likely at least one of x, y, and z will be a phosphate-containing group, either mono-, di-, or tri-phosphate and at least one will be HO- or H-. As will be readily appreciated,
20 the most likely identity of z will be HO- or H- indicating ribonucleotide or deoxyribonucleotide, respectively. Examples of such nucleotides include 5'-ribonucleoside monophosphates, 5'-ribonucleoside diphosphates, 5'-ribonucleoside triphosphates, 5'-deoxyribonucleoside monophosphates,
25 5'-deoxyribonucleoside diphosphates, 5'-deoxyribonucleoside triphosphates, 5'p-ribonucleoside-3'p, and 5'p-deoxyribonucleoside-3'p. More specific examples include modified nucleotides of this type in which A is biotin or iminobiotin, the chemical linkage is

30

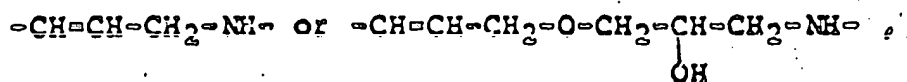

and B is uracil or cytosine.

35 The general synthetic approach adopted for introducing the linker arm and probe moiety onto the base is discussed hereinabove. (See especially, J.L. Ruth and D.E.

Bergstrom, J. Org. Chem., 43, 2870, 1978; D.E. Bergstrom
 M.K. Ogawa, J. Amer. Chem. Soc. 100, 8106, 1978; and C.F.
 Bigge, P. Kalaritis, J.R. Deck and M.P. Mertes, J. Amer.
 Chem. Soc. 102, 2033, 1980.) However, the olefin substi-
 5 tuents employed herein have not been used previously. To
 facilitate attachment of probe moiety A, it has been fou-
 nd particularly desirable to employ olefins with primary
 amine functional groups, such as allylamine [AA] or allyl-
 (3-amino-2-hydroxy-1-propyl) ether [NAGE], which permit
 10 probe attachment by standard amine modification reactions,
 such as,

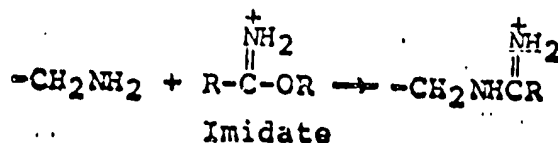

15

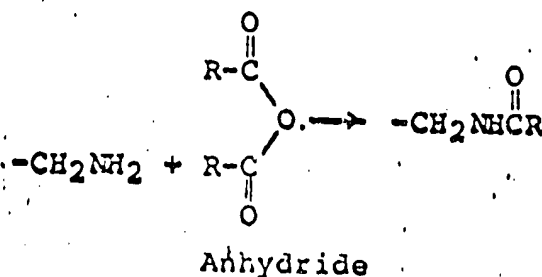

20

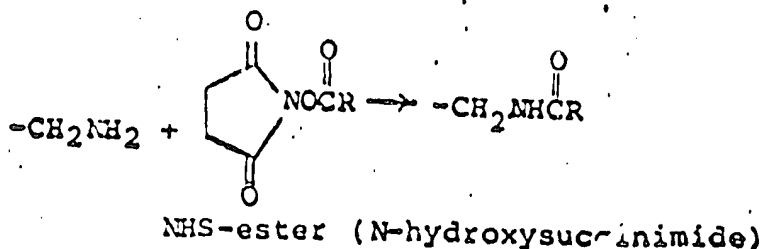

25

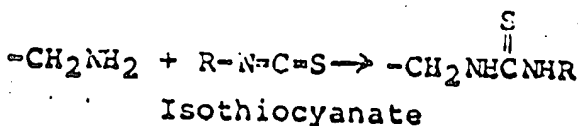

30

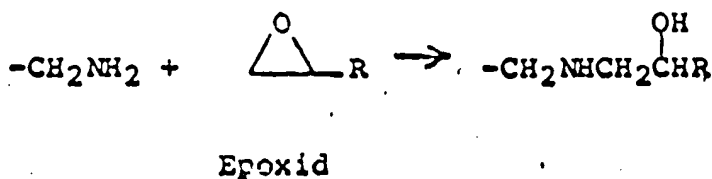

35

Because of ease of preparation it has been found preferable to use NHS-esters for probe addition. However, olefin linker arms with other modifiable functional groups, such as thiols, carboxylic acids, epoxides, and the like, can also be employed. Furthermore, both linker arm and probe can be added in a single-step if deemed desirable.

Specifically, modified nucleotides having the structure:

10

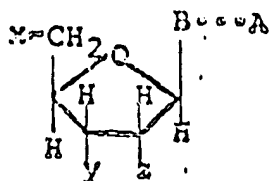

15 wherein B represents a purine, 7-deazapurine, or pyrimidine moiety covalently bonded to the C^{1'}-position of the sugar moiety, provided that when B is purine or 7-deazapurine, it is attached at the N⁹-position of the purine or deazapurine, and when B is pyrimidine, it is attached
20 at the N¹-position;

wherein A represents a moiety consisting of at least three carbon atoms which is capable of forming a detectable complex with a polypeptide when the compound is incorporated into a double-stranded ribonucleic acid, deoxyribonucleic acid duplex, DNA-RNA hybrid;
25

wherein the dotted line represents a chemical linkage joining B and A, provided that if B is purine, the linkage is attached to the 8-position of the purine, if 7-deazapurine, the linkage is attached to the 7-position of the deazapurine, and if B is pyrimidine, the linkage is attached to the 5-position of the pyrimidine; and
30

wherein each of x, y, and z represents

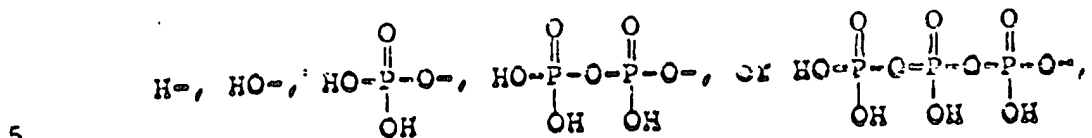

can be prepared by:

(a) reacting a compound having the structure:

10

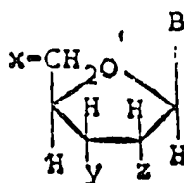

15

with a mercuric salt in a suitable solvent under suitable conditions so as to form a mercurated compound having the structure:

20

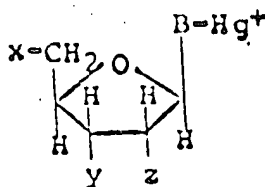

25

(b) reacting said mercurated compound with a chemical moiety reactive with the -Hg⁺ portion of said mercurated compound and represented by the formula ...N, said reaction being carried out in an aqueous solvent and in the presence of K₂PdCl₄ under suitable conditions so as to form a compound having the structure:

30

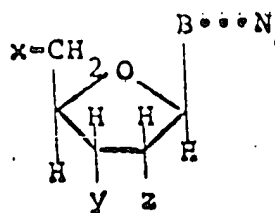

35

wherein N is a reactive terminal functional group or is A; and

5 (c) recovering said compound as said modified nucleotide when N is A, or when N is a reactive terminal group, reacting said compound with a compound having the structure M-A, wherein M represents
10 a functional group reactive with N in an aqueous solvent under suitable conditions, so as to form said modified nucleotide, which is then recovered.

The following schema is illustrative:

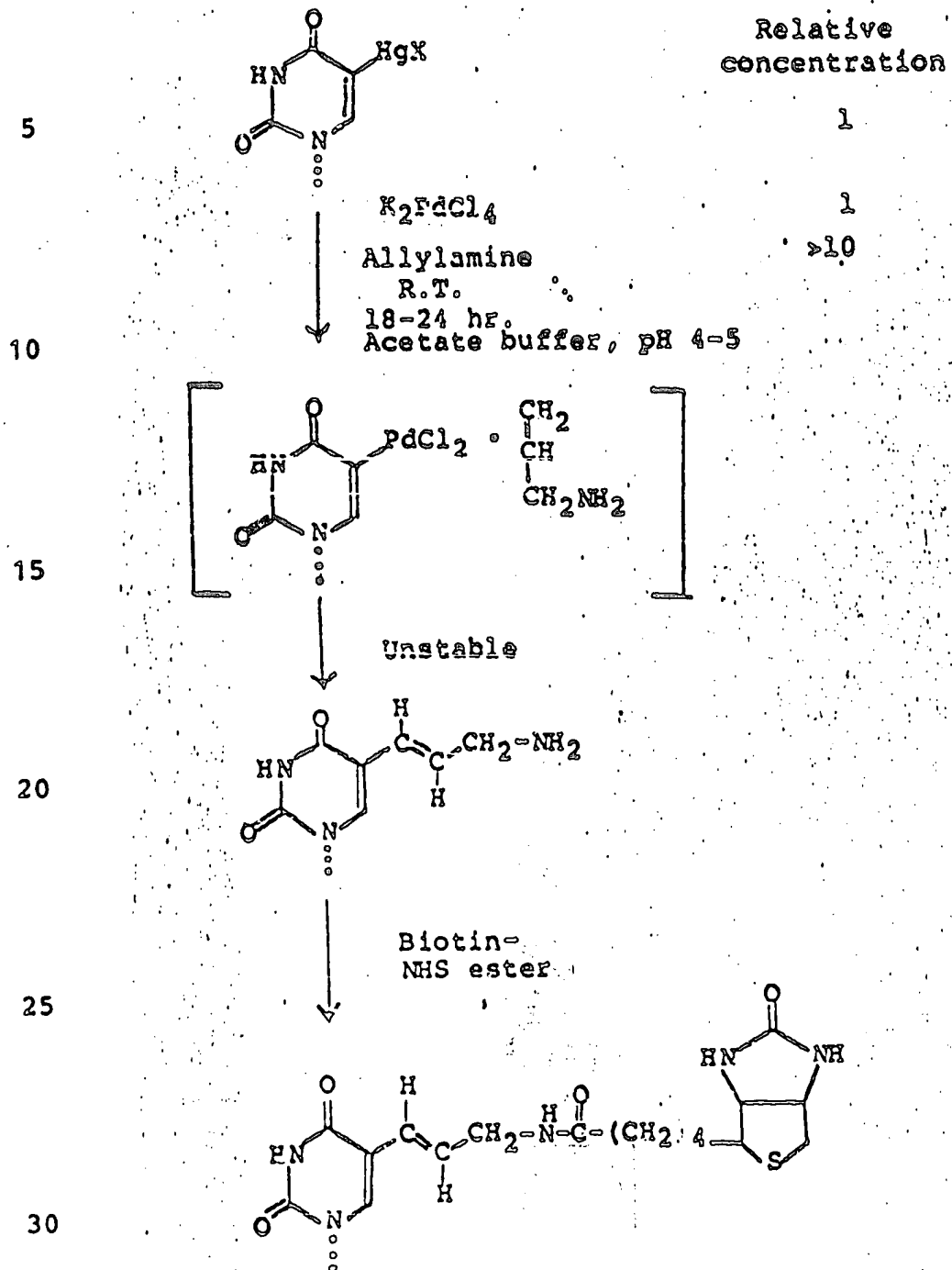

Although the reactions can be carried out at hydrogen ion concentrations as low as pH 1, or as high as pH 14, it is preferred to operate in the range from about 4 to 8. This is especially true when dealing with unstable compounds such as nucleoside polyphosphates, polynucleotides,

and nucleotide coenzymes which are hydrolyzed at pH's outside this range. Similarly, it is preferred to operate at a temperature in the range from about 20° C to 30° C to avoid possible decomposition of labile organic substrates. However, the reactions can be carried out at temperatures from about 5° C to 100° C. As is usual with chemical reactions, higher temperatures promote the reaction rate and lower temperatures retard it. Thus, in the temperature range from 5° C to 100° C, the optimum reaction time may vary from about 10 minutes to 98 hours. In the preferred temperature range, reaction times normally vary from about 3 to 24 hours.

The preferred procedure for maintaining the pH in the desired range is through the use of buffers. A variety of buffers can be employed. These include, for example, sodium or potassium acetate, sodium or potassium citrate, potassium citrate-phosphate, tris-acetate and borate-sodium hydroxide buffers. The concentration of buffer, when employed, can vary over a wide range, up to about 2.0 molar.

While a particular advantage of the mercuration and palladium catalyzed addition reactions is that they can be carried out in water, small amounts of an organic solvent can be usefully included as a solubility aid. The organic solvents usually chosen are those which are miscible with water. These may be selected from ethers, alcohols, esters, ketones, amides, and the like such as methanol, ethanol, propanol, glycerin, dioxane, acetone, pyridine and dimethylformamide. However, since it has been observed that the presence of alcohols, such as methanol, often results in alkoxy-addition across the olefin double bond, any organic solvent used as a solubility aid should be chosen carefully. Introduction of alkoxy substituents to the α - or β - exocyclic carbon atoms often results in the production of compounds which are utilized much less

efficiently as enzyme substrates.

Although various mercuric salts may be utilized, the presently preferred salt is mercuric acetate. Also, as indicated previously, the compounds may be prepared by first adding a linker arm and then the moiety A, or by adding a linker arm to which A is already attached. Thus, the chemical moiety represented by the formula $\cdots N$ may be any one of the numerous entities which ultimately result in production of the desired compounds.

10

Examples include $-\text{CH}=\text{CH}-\text{CH}_2-\text{NH}_2$:

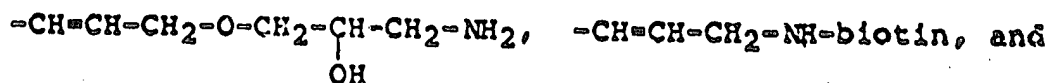

15

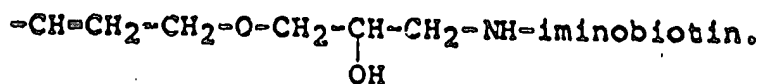

The amounts of the reactants employed in these reactions may vary widely. However, in general the amounts of unmercurated compound, mercurated compound, and palladium-containing compound will be substantially stoichiometric whereas the mercuric salt and compound $\cdots N$ will be present in molar excess, e.g. 5 - 20 moles of $\cdots N$ or of mercuric salt per mole of mercurated compound or unmercurated compound, respectively. In practice, amounts will vary depending upon variations in reaction conditions and the precise identity of the reactants.

Having the biotin probe directly attached to nucleotide derivatives that are capable of functioning as enzyme substrates offers considerable versatility, both in the experimental protocols that can be performed and in the detection methods (microscopic and non-microscopic) that can be utilized for analysis. For example, biotin nucleotides can be introduced into polynucleotides which are in the process of being synthesized by cells or crude cell extracts, thus making it possible to detect and/or

isolate nascent (growing) polynucleotide chains. Such a procedure is impossible to do by any direct chemical modification method. Furthermore, enzymes can be used as reagents for introducing probes such as biotin into highly selective or site-specific locations in polynucleotides; the chemical synthesis of similar probe-modified products would be extremely difficult to achieve at best.

10 The synthesis of nucleotides containing biotin or iminobiotin was achieved as detailed in the examples set forth hereinafter. Pyrimidine nucleoside triphosphates containing either of these probes attached to the C-5 carbon atom were good to excellent substrates for a wide variety of purified nucleic acid polymerases of both prokaryotic and eukaryotic origin. These include DNA polymerase I or E. coli, bacteriophage T4 DNA polymerase, DNA polymerases α and β from murine (A-9) and human (HeLa) cells, and the DNA polymerase of Herpes simplex virus. Confirming data were obtained with E. coli DNA polymerase I using either the nick-translation condition of Rigby, et al. (P.W.J. Rigby, M. Dieckmann, C. Rhodes and P. Berg, J. Mol. Biol. 113, 237, 1977) or the gap-filling reaction described by Bourguignon et al. (G.J. Bourguignon, P. J. Tattersall and D.C. Ward, J. Virol. 20, 290, 1976). Bio-dUTP has also been found to function as a polymerase substrate both in CHO cells, permeabilized by treatment with lysolecithin according to the method of Miller, et al. (M.R. Miller, J.C. Castellot, Jr. and A.B. Pardee, Exp. Cell Res. 120, 421, 1979) and in a nuclear replication system prepared from Herpes simplex infected BHK cells. Although biotinyl ribonucleoside triphosphates were found to function as substrates for the RNA polymerases of E. coli and bacteriophage T7, they are not utilized as efficiently as their deoxyribonucleotide triphosphate counterparts. Indeed, they are incorporated poorly, if at all, by the eukaryotic RNA polymerases examin-

ed (HeLa cell RNA polymerase III, calf thymus RNA polymerase II and mouse cell RNA polymerase II). While this limited range of substrate function does restrict the utility in some in vivo or in vitro transcription studies, 5 biotin-labeled RNA probes can be prepared enzymatically from DNA templates using E. coli or T7 RNA polymerases or by 3' end-labeling methods using RNA ligase with compounds such as biotinyl-pCp. The AA- and NAGE-derivatives of UTP are, however, substrates for the eukaryotic RNA 10 polymerases mentioned above. With the availability of antibodies to these analogs, the isolation of nascent transcripts by immunological or affinity procedures should be feasible.

15 The enzymatic polymerization of nucleotides containing biotin or iminobiotin substituents was not monitored directly, since neither of these probes were radiolabeled. However, two lines of experimental evidence clearly show that the biotinyl-nucleotides were incorporated. The first 20 is that polynucleotides synthesized in the presence of biotin-nucleotides are selectively retained when chromatographed over avidin or streptavidin affinity columns. (Tables I and II). For example, whereas normal DNA, nick translated with ^{32}p -dAMP, is quantitatively eluted 25 upon the addition of 0.5 M NaCl, the vast majority of biotinyl-DNA or iminobiotinyl-DNA remains bound to the resin even after extensive washing with high salt, urea, guanidine-HCl, formamide or 50 mM NaOH. The small fraction of the radiolabel eluted by these washing conditions is 30 not retained when applied to the resin a second time, suggesting that radioactivity is associated with DNA fragments which are free of biotin substitution. The second line of evidence is that only biotin-labeled polynucleotides are immunoprecipitated when treated with purified 35 anti-biotin IgG followed by formalin-fixed Staphylococcus aureus. (Table III). It is clear from the data in these tables that extremely small amounts of biotin can be de-

tected by this method. These results also show that the biotin molecule can be recognized by avidin, streptavidin or specific antibodies while the DNA is still in its native, double-stranded form, a condition that is absolutely essential if the antibody-binding or avidin-affinity approaches are to be useful in probe detection employing hybridization techniques.

10

TABLE I

SELECTIVE RETENTION OF BIOTINYIZED DNA
ON AVIDIN-SEPHAROSE

15

<u>Eluent</u>		<u>% DNA Retained on Resin</u>	
		Bio-DNA (%)	T-DNA
<u>Load</u> - 3×10^5 cpm			
	10 mM Tris 7.5 + 0.2 M NaCl	100	100%
20	(1) 0.5 M NaCl	100	0.1
	(2) 1.0 M NaCl	99.7	<0.01
	(3) 8 M Urea	100	<0.01
	(4) 6 M guanidine-HCl	95.2	<0.01
25	(5) 99% formamide	94.7	<0.01
	(6) 2 mM Biotin	97.6	<0.01
	(7) 50 mM NaOH	89.5	<0.01

TABLE II

Affinity Chromatography of Iminobiotin-dUTP
and Iminobiotinized - DNA on Streptavidin-Sepharose

5	<u>Eluent</u>	<u>% Retained on SA-Sepharose</u>		
		T-DNA	³ H-IB-dUTP	IB-DNA
	Load - 10 mM Tris-HCl, 8.3 50 mM NaCl	8.7	100	99.7
10	(1) 0.1 M NaCl	<0.1	100	99.7
	(2) 1.0 M NaCl	<0.01	100	99.4
	(3) 8 M Urea	<0.01	97.5	98.5
	(4) 6 M guanidine-HCl	<0.01	97.0	97.0
	(5) 50 mM NH ₄ -acetate, pH 4.0	<0.01	<0.01	95.5
15	(u) 50 mM NH ₄ -acetate, pH 4.0 2 mM biotin	<0.01	<0.01	<0.01

20

TABLE III

SELECTIVE IMMUNOPRECIPITATION OF BIO-DNA
WITH ANTI-BIOTIN IgG and STAPH AUREUS

25	<u>DNA*</u>	<u>Antibody</u>	<u>CPM in Immuno ppt.</u>	<u>CPM in Supernatant</u>
	T-DNA	-	70	4867
	T-DNA	Anti-Bio IgG	87	5197
	T-DNA	Non-immune IgG	55	5107
30	Bio-DNA	-	53	3886
	Bio-DNA	Anti-Bio IgG	3347	736
	Bio-DNA	Non-immune IgG	60	3900

35 *N.T. pBR-322 DNA, ³²P-labeled; 1% Biotin substitution.
Specific activity, 2 x 10⁷ cpm/μg
Biotin detection 0.001-0.01 pmoles.

Thus, it is possible to prepare novel compounds having the structure:

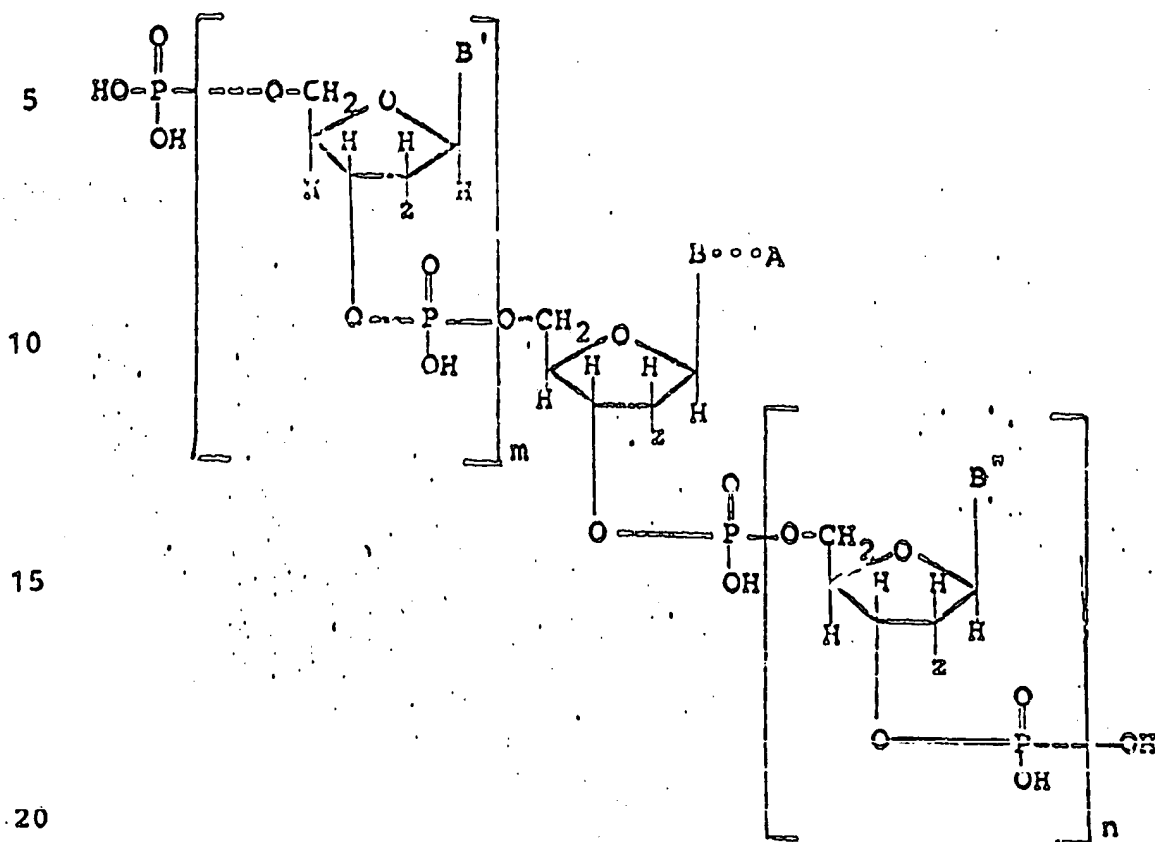

wherein each of B, B', and B'' represents a purine, deazapurine, or pyrimidine moiety covalently bonded to the C^{1'}-position of the sugar moiety, provided that whenever B, B', or B'' is purine or 7-deazapurine, it is attached at the N⁹-position of the purine or deazapurine, and whenever B, B', or B'' is pyrimidine, it is attached at the N¹-position;

30 wherein A represents a moiety consisting of at least three carbon atoms which is capable of forming a detectable complex with a polypeptide when the compound is incorporated into a double-stranded duplex formed with a complementary ribonucleic or deoxyribonucleic acid molecule;

35

wherein the dotted line represents a linkage group joining B and A, provided that if B is purine, the linkage

is attached to the 8-position of the purine, if B is 7-deazapurine, the linkage is attached to the 7-position of the deazapurine, and if B is pyrimidine, the linkage is attached to the 5-position of the pyrimidine;

5

wherein z represents H- or HO-; and

wherein m and n represent integers from 0 up to about 100,000.

10

Of course, it should be readily understood that in general m and n will not simultaneously be 0 since, in that event, the compound becomes merely a modified nucleotide as described previously. In general B' and B'' will vary within the same oligo- or polynucleotide, being alternatively uracil, cytosine, thymine, guanine, adenine, or the like. Also, in general, the variation will correspond to the ordered sequence of nucleotides which codes for the synthesis of peptides according to the well known Genetic Code. However, it is intended that the structure shown also embrace polynucleotides such as poly C, poly U, poly r(A-U), and poly d(A-U) as well as calf thymus DNA, ribosomal RNA of E. coli or yeast, bacteriophage RNA and DNA (R17, fd), animal viruses (SV40 DNA), chromosomal DNA, and the like, provided only that the polynucleotides be modified in accordance with this invention.

It is also to be understood that the structure embraces more than one modified nucleotide present in the oligomer or polymer, for example, from two to thirty modified nucleotides. The critical factor in this regard is that the number of modifications not be so great that the polynucleotide is rendered ineffective for the intended use.

35 Finally, it should be understood that modified oligo- and polynucleotides can be joined to form larger entities having the same structure so long as terminal groups are

rendered compatible or reactive.

These compounds can be made by enzymatic polymerization of appropriate nucleotides, especially nucleotide triphosphates in the presence of a nucleic acid template which directs synthesis under suitable conditions. Such conditions can vary widely depending upon the enzyme employed, amounts of nucleotides present, and other variables. Illustrative enzymes include DNA polymerase I of E. coli, bacteriophage T4 DNA polymerase, DNA polymerases α and β from murine and human (HeLa) cells, DNA polymerase from Herpes simplex virus, RNA polymerase of E. coli, RNA polymerase of bacteriophage T7, eukaryotic RNA polymerase including HeLa cell RNA polymerase III, calf thymus RNA polymerase II, and mouse cell RNA polymerase II.

Also, the compounds can be prepared by terminal addition to oligo- or polynucleotides to produce compounds in which m or n is 0 depending upon whether the addition is at the 5' or 3' position. Moreover, the compounds such as pCp or pUp in which the base is biotinized can be added to existing molecules employing the enzyme RNA ligase.

Modified oligo- and polynucleotides can also be prepared by chemical modification of existing oligo- or polynucleotides using the approach described previously for modification of individual nucleotides.

The various modified nucleotides, oligonucleotides, and polynucleotides of this invention may be detected by contacting the compounds with polypeptides which are capable of forming complexes therewith under suitable conditions so as to form the complexes, provided that the polypeptides include one or more moieties which can be detected when the complex or complexes is or are formed, generally by means of conventional detection techniques.

One polypeptide detector for the biotinyl-type probe is avidin. The avidin-biotin interaction exhibits one of the tightest non-covalent binding constants ($K_{dis} = 10^{-15}$) seen in nature. If avidin is coupled to potentially demonstrable indicator molecules, e.g., fluorescent dyes (fluorescein, rhodamine), electron-dense reagents (ferritin, hemocyanin, colloidal gold), or enzymes capable of depositing insoluble reaction products (peroxidase, alkaline phosphatase) the presence, location and/or quantity of the biotin probe can be established.

Avidin has, unfortunately, one property that makes it less desirable as a biotin-indicator protein when used in conjunction with nucleic acids or chromatin material. It has been reported (M.H. Heggeness, *Stain Technol.*, 52, 165, 1977; M.H. Heggeness and J.F. Ash, *J. Cell. Biol.*, 73, 783, 1977; E.A. Bayer and M. Wilchek, *Methods of Biochemical Analysis* 26, 1, 1980) that avidin binds tightly to condensed chromatin or to subcellular fractions that contain large amounts of nucleic acid in a manner which is independent of its biotin-binding property. Since avidin is a basic glycoprotein with a pI of 10.5, its histone-like character or its carbohydrate moieties are most likely responsible for these observed non-specific interactions.

A preferred probe for biotin-containing nucleotides and derivatives is streptavidin, an avidin-like protein synthesized by the soil organism Streptomyces avidinii. Its preparation and purification is described in Hoffman, et al., *Proc. Natl. Acad. Sci.*, 77, 4666 (1980). Streptavidin has a much lower pI (5.0), is non-glycosylated, and shows much lower non-specific binding to DNA than avidin, and therefore offers potential advantages in applications involving nucleic acid detection methodology.

A most preferred protein for biotin-like probe detection.

is nonspecific rabbit IgG, antibiotin immunoglobulin. This compound was prepared by immunizing rabbits with bovine serum albumin conjugated biotin as described previously (M. Berger, *Methods in Enzymology*, 62, 319 [1979]) and purified by affinity chromatography. Although the association constant of immunoglobulin-haptens have values of K_{assn} (10^6 to 10^{10}) which are considerably lower than for avidin-biotin complexes, they are substantially equivalent to those observed with the avidin-iminobiotin complex. Furthermore, the anti-biotin antibodies have proven extremely useful in detecting specific polynucleotide sequences on chromosomes by in situ hybridization since little, if any, non-specific binding of the antibody to chromatin material occurs.

The modified polynucleotides of this invention are capable of denaturation and renaturation under conditions compatible with their use as hybridization probes. An analysis of the thermal denaturation profiles and hybridization properties of several biotin-substituted DNA and RNA polymers clearly indicates this. For example, pBR 322 DNA or λ DNA, nick translated to introduce approximately 10-100 biotin residues per kilobase, have T_m values essentially identical to that of the control, biotin-free DNAs. Furthermore, ^{32}P -labeled, biotin-substituted, pBR 322 DNA, exhibited the same degree of specificity and autoradiographic signal intensity as control, thymidine-containing DNA, when used as a hybridization probe for detecting bacterial colonies containing the plasmid.

In DNA duplexes, such as MVM RF DNA, in which every thymidine residue in one strand (1250 in toto per 5 Kb) is replaced by a biotinyl-nucleotide, the T_m is only 5° C less than that of the unsubstituted control. Although the T_m of poly d(A-bioU) in which each base pair contains a bio-dUMP residue is 15° C lower than the poly d(A-T) control, the degree of cooperativity and the extent of hyp-

- erchromicity observed both during denaturation and rena-
turation were the same for the two polymers. A parallel
analysis of RNA duplexes and DNA/RNA hybrids indicates
that their T_m 's also decrease as the biotin-content of
5 the polymer increases. However, it is clear that a sub-
stantial number of biotin-molecules can be introduced with-
out significantly altering the hybridization characteris-
tics of the polymers.
- 10 These results strongly suggested that biotin-substituted
polynucleotides could be used as probes for detecting and/
or localizing specific polynucleotide sequences in chro-
mosomes, fixed cells, or tissue sections.

The general protocol for detecting the biotin-substituted probe is schematically illustrated as follows:

GENERAL PROTOCOL FOR PROBE DETECTION
VIA *IN SITU*, COLONY, OR NORTHERN/SOUTHERN
HYBRIDIZATION METHODS

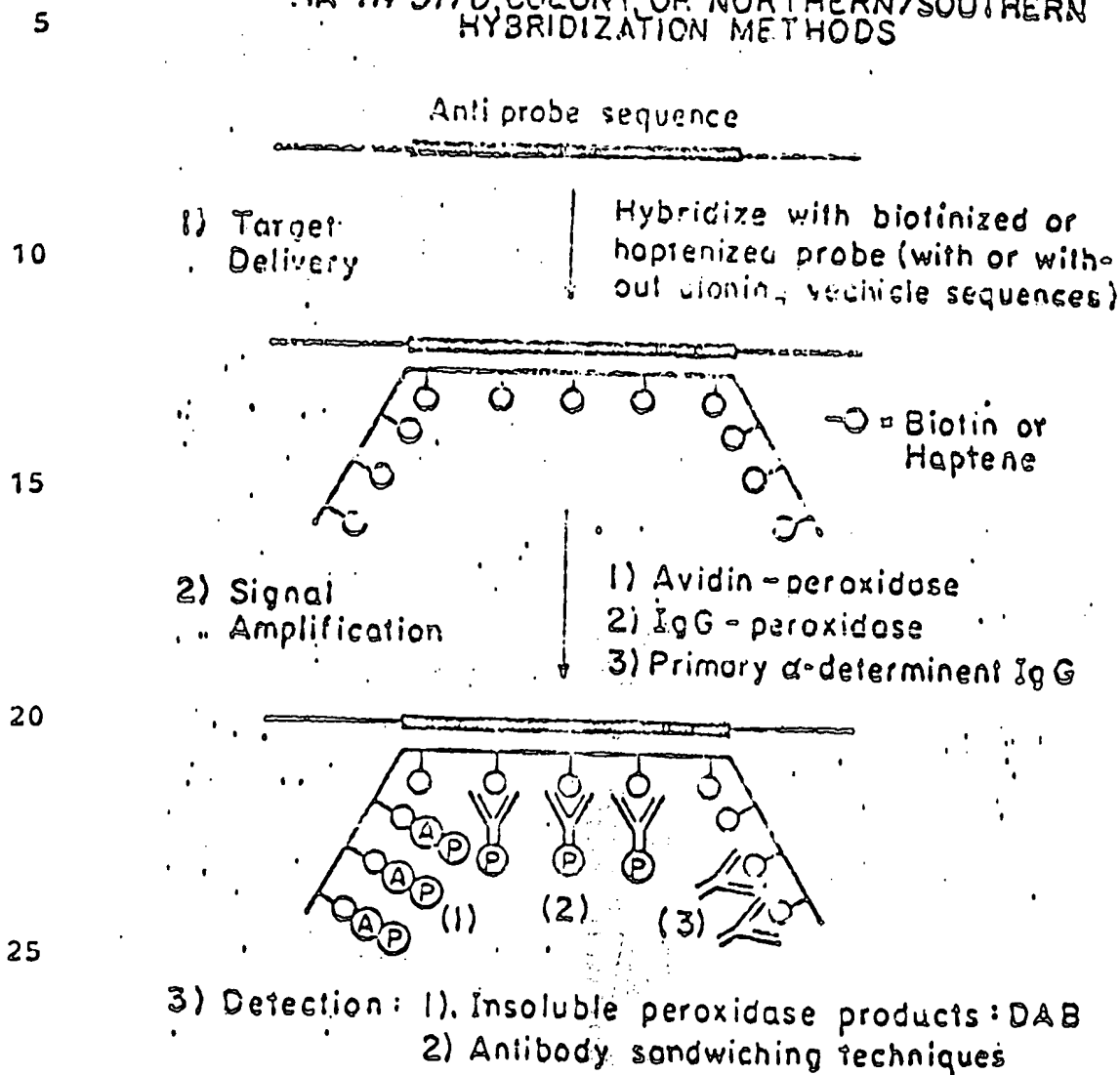

This general scheme illustrates only procedures used for gene mapping (cytogenetics), and recombinant DNA-technologies. However, it can be equally well applied to the detection of nucleic acid sequences of bacterial, viral, fungal or parasite origin in clinical samples and this forms the basis of a powerful new approach to clinical diagnostics which does not rely on the use of radioisotopes.

Immunological and histochemical methods for the detection of biotin have shown that the basic approach is useable for a rapid method of gene mapping in situ hybridization and non-radioactive procedures for detecting specific nucleic acid sequences by blotting hybridization methods. Use may be made of this technology in development of new clinical diagnostic procedures.

Using this approach, it is possible to determine the presence of a specific deoxyribonucleic or ribonucleic acid molecule, particularly such a molecule derived from a living organism, e.g. bacteria, fungus, virus, yeast, or mammal. This in turn permits diagnosis of nucleic acid-containing etiological agents in a patient or other subject.

Moreover, it provides a method for screening bacteria to determine antibiotic resistance. Thus, for example, penicillin resistance in Streptococcus pyogenes or Neisseria meningitidis; tetracycline resistance in Staphylococcus aureus, Candida albicans, Pseudomonas aeruginosa, Streptococcus pyogenes, or Neisseria gonorrhoeae; and aminoglycoside resistance in Mycobacterium tuberculosis can be determined.

In these methods a polynucleotide is prepared which is complementary to the nucleic acid sequence which characterizes the organism or its antibiotic resistance and which additionally includes one or more modified nucleotides according to this invention. This polynucleotide is hybridized with nucleic acid obtained from the organism under scrutiny. Failure to hybridize indicates absence of the organism or of the resistance characteristic. Hybridized nucleic acid duplexes are then identified by forming a complex between the duplex and a suitable polypeptide which carries a detectable moiety, and detecting the presence of the complex using an appropriate detection technique. Positive detection indicates that the

complex, the duplex and therefore the nucleic acid sequence of interest are present.

This approach can be extended to the diagnosis of genetic disorders, such as thalassemia and sickle cell anemia. The deoxyribonucleotide acid gene sequence whose presence or absence (in the case of thalassemia) is associated with the disorder can be detected following hybridization with a polynucleotide probe according to this invention based upon complex formation with a suitable detectable polypeptide.

The mapping of genes or their transcripts to specific loci on chromosomes has been a tedious and time-consuming occupation, involving mainly techniques of cell-fusion and somatic cell genetics. Although in situ hybridization has been employed successfully for mapping single-copy gene sequences in species that undergo chromosomes polyploidization, such as Drosophila, detection of unique sequence genes in most higher eukaryotic chromosomes has been extremely difficult, if not impossible, using standard hybridization methods. The necessity for polynucleotide probes of very high specific radioactivity to facilitate autoradiographic localization of the hybridization site also results in rapid radiodecomposition of the probe and a concomitant increase in the background noise of silver grain deposition. The use of hybridization probes with low to moderate specific radioactivities requires exposure times of many days or weeks, even to detect multicopy sequences, such as ribosomal RNA genes or satellite DNA. Since recombinant DNA technology has made feasible the molecular cloning of virtually every single-copy sequence found in eukaryotic cells, it would be extremely beneficial to have a rapid and sensitive method for mapping the chromosomal origin of such cloned genomic fragments.

Modified nucleotides may be used in a method of gene map-

ping by in situ hybridization which circumvents the use of radioisotopes. This procedure takes advantage of a thymidine analogue containing biotin that can be incorporated enzymatically into DNA probes by nick translation.

5 After hybridization in situ the biotin molecules serve as antigens for affinity purified rabbit anti-biotin antibodies. Immunofluorescent antibody sandwiches made with fluorescein-labeled goat anti-rabbit IgG allow for rapid and specific cytogenetic localization of cloned gene sequences as green-yellow bands. This method offers four major advantages over conventional autoradiographic methods of in situ gene localization; less background noise, an increase in resolving power between bands; a decrease in the time required to determine the site of probe hybridization; and chemically stable hybridization probes.

10 This method has been applied successfully to the localization of reiterated and unique DNA sequences in the polytene chromosome of Drosophila melanogaster and satellite DNA on mouse metaphase chromosomes.

20 Thus it has been found that polytene chromosomes could be used as a test system for establishing the efficacy of probes using the modified nucleotides according to the instant invention as detected by indirect immunofluorescence for in situ gene mapping. The probes included a variety of cloned Drosophila sequences obtained from Otto Schmidt and Dieter Söll, such as tRNA genes cloned in plasmid vectors with inserts of sizes ranging from about 5 to about 22 kilobases. Many of these clones have already

25 been assigned to specific bands on the Drosophila chromosome map by conventional in situ hybridization methods employing radioisotopes.

30 DNA probes were nick translated in the presence of Bio-dUTP. Occasionally ^3H dATP and/or ^3H dCTP was included in the nick translation reaction mixture. This allowed both autoradiographic and immunofluorescent localization

of a sequenc on a single chromosome spread. In situ hybridization was performed as described in M.L. Pardue, and J.G. Gall, *Methods in Cell Biol.*, 10, 1 (1975). After the final 2 x SSC wash to remove unhybridized probe, 5 the slides were rinsed with PBS (phosphate buffered saline) and incubated at 37° C with 2.5 μ g/ml Rabbit anti-biotin in PBS and 10 mg/ml BSA for 2-16 hours. This was followed by incubation of the slides with FITC labeled 10 in PBS and 10 mg/ml BSA) for one-four hours. Evans Blue was often required as a red counterstain to see the chromosomes with fluorescent illumination.

When plasmids pBR 17D and pPW 539 containing 5 Kb and 32 Kb 15 inserts, respectively, were hybridized by this method, it was found that the pattern of hybridization is reproducible from spread to spread and is observed unambiguously on greater than 90% of the chromosome spreads on a given slide.

20 The cloned transposable element pAC 104 is known to map at many sites along the Drosophila genome. Comparison of the autoradiograph and the fluorescent picture obtained by in situ hybridization of this probe illustrates a major 25 advantage of this method, i.e., that where diffuse regions of silver grains appear on an autoradiograph, doublets or a series of bands are discernible by immunofluorescent labeling.

30 The other immediately obvious advantage of this method is the tremendous decrease in time required for gene assignments to be made by indirect immunofluorescence. An assignment of a DNA fragment to a specific band can be made within six hours of hybridization. This is in comparison 35 to days or weeks required for autoradiographic exposure methods. This factor in combination with increased resolution, makes the use of modified nucleotides detected by

indirect immunofluorescence immediately preferable to more classical methods.

It has been shown that this immunological method also works with mammalian chromosomes wherein satellite DNA has been mapped to the centromeric regions of mouse metaphase chromosomes. The result provides a basic foundation for the development of a simple gene mapping procedure for single copy (unique) sequences in chromosomes from human and other mammals. Such a procedure should greatly facilitate our understanding of the genetic organization of the chromosome and make clinical cytogenetic diagnosis much more rapid and practical.

While a single-step "antibody sandwich" method in which the chromosome spread is challenged, post-hybridization, with rabbit anti-biotin IgG may succeed, this protocol may not generate sufficient fluorescence for unambiguous gene assignments. However, a much stronger fluorometric signal can be achieved by using the "haptene-antibody sandwich technique" described by Lamm, et al., (1972); Wofsy, et al., (1974). In this procedure the primary antibody, in our case monospecific, rabbit anti-biotin IgG, is chemically modified with a haptene reagent, such as 2, 4-dinitrofluorobenzene, preferably while the immunoglobulin is bound to an antigen affinity column (biotin-Sepharose TM). As many as 15-20 haptene (DNP) groups can be coupled to the primary antibody without decreasing its antigen binding affinity or specificity (Wallace and Wofsy, 1979). If the primary antibody treatment of the test sample is followed by an incubation with a fluorescently labeled anti-hapten IgG antibody, rather than a fluorescently labeled anti-IgG, a 5-7 fold increase in fluorescence signal can be achieved. Since one also has available monospecific guinea pig anti-DNP IgG, we can haptene this secondary antibody with biotin and thus generate two anti-hapten IgG populations, DNP-labeled anti-biotin IgG and biotin-labeled anti-DNP IgG. If these can be used alternately

to achieve several rounds of hapten-antibody sandwiching and then followed with fluorescently labeled protein A from Staphylococcus aureus, which binds specifically to IgG molecules from many mammalian species, it could result
5 in an enormous amplification of the primary antibody signal with its concomitant utility.

The protein streptavidin from Streptomyces avidini is a potential alternative to anti-biotin IgG as a vehicle to
10 specifically direct a coupled visualization system [e.g., fluorescent probes (above) or histochemical reagents (below)] to the site of the hybridized biotin-containing polynucleotide. One of streptavidin's advantages over anti-biotin IgG is that its affinity for biotin is $K_{assn} = 10^{15}$
15 whereas association constants for haptene-IgG interactions are 10^7 to 10^{10} . The fast reaction rate and extreme affinity mean that the time required to localize the biotinized probe will be minutes with streptavidin versus hours with immunologic reagents.

20 Initial evaluations of a streptavidin detection system are currently in progress. Polytene chromosomes hybridized with biotinized DNA probes will be incubated with streptavidin followed by a subsequent incubation with bovine
25 serum albumin which has been doubly labeled with biotin and FITC (FITC, biotinyl-BSA). Since only one of the four streptavidin subunits is likely to be involved in binding at each biotinized DNA site, potentially one labeled BSA
30 molecule can bind to each of the remaining three nonconjugated subunits of the streptavidin-biotinyl nucleotide complex. The fluorescence signal from this single streptavidin + FITC, biotinyl-BSA layer will be compared with a control using the basic "antibody sandwich method" described earlier.

35 If the "antibody sandwich" and streptavidin + FITC, biotinyl-BSA detection intensities are comparable, one can

attempt to enhance the streptavidin + FITC, biotinyl-BSA system to single-copy sensitivity in a manner that parallels the multiple "haptene-antibody sandwich" approach. Since some of biotin groups on BSA will not be bound to the first layer of streptavidin, a second layer of streptavidin can be added until sufficient signal is obtained. For example, if in the second layer, only two streptavidin protomers bind to each first-layer BSA and each of these streptavidin protomers binds three FITC-biotinyl BSA molecules, then the second layer intensity will be twice as great as that from the first layer; for the third layer, with analogous binding stoichiometries, the fluorescent intensity will be 12-fold that of the first layer, so the total intensity will rapidly increase with successively added layers.

There are plans to use a larger carrier protein such as thyroglobulin rather than BSA in order to maximize amounts of attached fluorescent and biotin probes. It may also be necessary to use a longer linker arm between the biotin probe and the carrier protein. A longer linker arm should sterically optimize the theoretical delivery of a biotinized fluorescent carrier molecule to each nonconjugated streptavidin subunit and maximize the number of streptavidin protomers in the subsequent layer which will bind to the biotinized fluorescent carrier. As before, appropriate controls will be done to insure that substitution of the carrier protein with fluorescent probes and biotin does not cause solubility and/or nonspecific binding problems.

The streptavidin-carrier protein delivery system has two significant advantages over the immunofluorescent approach in addition to its speed of delivery. First, only two protein components are needed to form the layers. Second, only the carrier protein needs to be modified and it is not necessary to maintain functional or even total struc-

tural integrity as long as the biotin groups are accessible to streptavidin.

An alternative to the fluorescence method for visualizing
5 hybridized probes is to direct enzymes such as peroxidase,
alkaline phosphatase, or β -galactosidase to the hybridization
site where enzymatic conversion of soluble substrates to insoluble
colored precipitates permits light microscope visualization. The
10 important advantage of this technique is that the histochemical
methods are 10 to 100-fold more sensitive than fluorescence
detection. In addition, the colored precipitates do not bleach
with extensive light exposure thus avoiding one of the general
disadvantages of fluorescent light microscopy. These enzymes
15 can be coupled to the final antibody instead of fluorescent
probes in the "haptene-antibody sandwich" technique using
bifunctional reagents such as glutaraldehyde or in the case of
peroxidase via oxidation of the peroxidase carbohydrate moieties
to aldehydes and coupling of these
20 residues with ϵ -amino groups of the desired protein. For the
streptavidin-biotinized carrier protein method, an enzyme with
biotinyl groups coupled to it could replace a fluorescently-
biotinized carrier system. Alternately, the enzyme could be
coupled via biotin to the last layer of streptavidin with
25 amplification of streptavidin sites being built up in preceding
layers using biotinized BSA or thyroglobulin. We will begin
developing the necessary histochemical reagents and the appropriate
substrate/insoluble product combinations for visualizing in situ
30 hybridizations without background problems in the near future.
The histochemical approaches to signal amplification should
therefore be ready for trial in the summer of 1981.

35 Detecting and/or imaging very low levels of fluorescent light
is possible using currently available image intensifiers or
systems composed of lasers and photomultipliers.

These methods permit the detection of light down to the level of individual photons. With suitable digital processing systems, images can be produced in which each point, i.e. each pixel, of the image is strictly proportional to the number of photons emitted by a point at the object. Using systems of this kind or flow systems in which the cells or parts of cells flow past a laser beam, one can obtain detection sensitivity increases for fluorescent material of factors between 100 and 1000 beyond that which can be detected by the eye. This increase is sufficient to detect the fluorescence of single copy genes.

In a preferred modification, analogs of dUTP and UTP that contain a biotin molecule covalently bound to the C-5 position of the pyrimidine ring through an allylamine linker arm have been synthesized. These biotinyl-nucleotides are efficient substrates for a variety of DNA and RNA polymerases in vitro. DNA containing low levels of biotin substitution (50 molecules or less/kilobase) has denaturation, reassociation and hybridization characteristics which are indistinguishable from that of unsubstituted control DNA.

Thus, this invention also provides a method of chromosomal karyotyping. In this method, modified polynucleotides are prepared which correspond to known genes and include modified nucleotides. These polynucleotides are hybridized with chromosomal deoxyribonucleic acid and the resulting duplexes contacted with appropriate polypeptides under suitable conditions to permit complex formation. The polypeptides include detectable moieties so that the location of the complexes can be determined and the location of specific genes thereby fixed.

Another embodiment of this invention involves detection of poly A-containing sequences using poly U in which some of the uracil bases have been modified to contain a probe. Yet another embodiment involves cyclic modified nucleot-

ides in which two of x, y and z are reacted to form the cyclic moiety

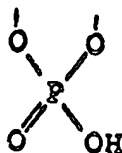

5

Such cyclic modified nucleotides may then be used to identify hormone receptor sites on cell surfaces which in turn can be used as a method of detecting cancer or tumor cells.

Finally tumor cells can be diagnosed by preparing polynucleotides which are modified according to this invention and are complementary to the messenger ribonucleic acid synthesized from a deoxyribonucleic acid gene sequence associated with the production of polypeptides, such as α -fetal protein or carcinoembryonic antigen, the presence of which is diagnostic for specific tumor cells. Hybridization and detection of hybrid duplexes thus would provide a method for detecting the tumor cells.

The examples which follow are set forth to illustrate various aspects of the present invention but are not intended to limit in any way its scope as more particularly set forth in the claims.

30

Example 1 and 2

Synthesis of biotinyl - UTP and biotinyl .. dUTP

a) Preparation of Mercurated Nucleotides
 35 UTP (570 mg, 1.0 mmole) or dUTP 554 mg, 1.0 mmole) was dissolved in 100 ml of 0.1 M sodium acetate buffer pH 6.0, and mercuric acetate (1.59 gm, 5.0 mmoles) added. Th

solution was heated at 50°C for 4 hours, then cooled on ice. Lithium chloride (392 mg, 9.0 mmoles) was added and the solution extracted six times with an equal volume of ethyl acetate to remove excess HgCl₂. The efficiency of the extraction process was monitored by estimating the mercuric ion concentration in the organic layer using 4, 4'-bis (dimethylamino)-thiobenzophenone (A.N. Chisophos, Analyst, 94, 392 (1969)). The extent of nucleotide mercuration, determined spectrophotometrically following iodination of an aliquot of the aqueous solution as described by Dale et al. (R.M.K. Dale, D.C. Ward, D.C. Livingston, and E. Martin, Nucleic Acid Res. 2, 915 [1975]), was routinely between 90 and 100%. The nucleotide products in the aqueous layer, which often became cloudy during the ethyl acetate extraction, were precipitated by the addition of three volumes of ice-cold ethanol and collected by centrifugation. The precipitate was washed twice with cold absolute ethanol, once with ethyl ether, and then air dried. These thus prepared mercurated nucleotides were used for the synthesis of the allylamine-nucleotides without further purification.

b) Synthesis of allylamine - dUTP and allylamine - UTP

The mercurated nucleotides (of step a) were dissolved in 0.1 M sodium acetate buffer at pH 5.0, and adjusted to a concentration of 20mM (200 OD/ml at 267 nm). A fresh 2.0 M solution of allylamine acetate in aqueous acetic acid was prepared by slowly adding 1.5 ml of allylamine (13.3 mmoles) to 8.5 ml of ice-cold 4 M acetic acid. Three ml (6.0 mmoles) of the neutralized allylamine stock was added to 25 ml (0.5 mmole) of nucleotide solution. One nucleotide equivalent of K₂PdCl₄, (163 mg, 0.5 mmole), dissolved in 4 ml of water, was then added to initiate the reaction. Upon addition of the palladium salt (Alfa-Ventron) the solution gradually turned black with metal (Hg and Pd) deposits appearing on the walls of the reaction vessel. After standing at room temperature for 18-24 hours, the reaction mixture was passed through a 0.45 mm membrane filter (nal-

gene) to remove most of the remaining metal precipitate. The yellow filtrate was diluted five-fold and applied to a 100 ml column of DEAE-Sephadex TM A-25 (Pharmacia). After washing with one column volume of 0.1 M sodium acetate buffer at pH 5.0, the products were eluted using a one liter linear gradient (0.1-0.6 M) of either sodium acetate at pH 8-9, or triethylammonium bicarbonate (TEAB) at pH 7.5. The desired product was in the major UV-absorbing portion which eluted between 0.30 and 0.35 M salt. Spectral analysis showed that this peak contained several products, final purification was achieved by reverse phase - HPLC chromatography on columns of Partisil - ODS2, using either 0.5M $\text{NH}_4\text{H}_2\text{PO}_4$ buffer at pH 3.3 (analytical separations), or 0.5 M triethylammonium acetate at pH 4.3 (preparative separations) as eluents. The 5'-triphosphates of 5-(3-aminopropen-1-yl) uridine (the allylamine adduct to uridine) were the last portions to be eluted from the HPLC column and they were clearly resolved from three, as yet uncharacterized, contaminants. These nucleotides were characterized by proton NMR elemental analysis tAA-dUTP ($\text{C}_{12}\text{H}_{16}\text{N}_3\text{O}_{14}\text{P}_3\text{Na}_4 \cdot 1\text{H}_2\text{O}$): theory C, 22.91; H, 2.88; N, 6.68; P, 14.77. Found, C, 23.10; H, 2.85; N, 6.49; P, 14.75. AA-UTP ($\text{C}_{12}\text{H}_{16}\text{N}_3\text{O}_{15}\text{P}_3\text{Na}_4 \cdot 4\text{H}_2\text{O}$): Theory, C 20.61; H, 3.46; N, 6.01; P, 13.3. Found C, 20.67; H, 4.11; N, 5.39; P, 13.54] spectrally and chromatographically.

c) Biotination of AA-dUTP or AA-UTP

Biotinyl-N-hydroxysuccinimide ester (NHSB) was prepared from biotin (Sigma) as described previously (H. Heitzmann and F.M. Richards, Proc. Natl. Acad. Sci. USA. 71, 3537 [1974]). AA-dUTP· H_2O (63 mg, 0.1 mmole) or AA-UTP· $4\text{H}_2\text{O}$ (70 mg, 0.1 mmole) was dissolved in 20 ml of 0.1 M sodium borate buffer at pH 8.5, and NHSB (34.1 mg, 0.1 mmole) dissolved in 2 ml of dimethyl formamide, was added. The reaction mixture was left at room temperature for four hours and then loaded directly onto a 30 ml column of DEAE-Sephadex TM A-25, preequilibrated with 0.1 M TEAB at pH 7.5.

The column was eluted with a 400 ml linear gradient (0.1-0.9 M) of TEAB. Fractions containing biotinyi-dUTP or biotinyl-UTP, which eluted between 0.55 and 0.65 M TEAB, were desalted by rotary evaporation in the presence of methanol and redissolved in water. Occasionally a slightly cloudy solution was obtained: this turbidity, due to a contaminant in some TEAB solutions, was removed by filtration through a 0.45 mm filter. For long term storage, the nucleotides were converted to the sodium salt by briefly stirring the solution in the presence of Dowex TM 50 (Na⁺ form). After filtration the nucleotide was precipitated by the addition of three volumes of cold ethanol, washed with ethyl ether, dried in vacuo over sodium hydroxide pellets, and stored in a dessicator at -20°C. For immediate use, the nucleotide solution was made 20 mM in Tris-HCl at pH 7.5, and adjusted to a final nucleotide concentration of 5 mM. Stock solutions were stored frozen at -20°C.

Elemental analysis of the bio-dUTP and bio-UTP products yielded the following results. Bio-dUTP (C₂₂ H₃₀ N₅ O₁₈ P₃ S₁ Na₄ · 1 H₂O). Theoretical; C, 29.80; H, 3.38; N, 7.89; P, 10.47; S, 3.61. Found; C, 30.14; H, 3.22; N, 7.63; P, 10.31; S, 3.70. Bio-UTP (C₂₂ H₃₀ N₅ O₁₉ P₃ S₁ Na₄ · 3 H₂O): Theoretical; C, 29.15; H, 3.19; N, 7.45; P, 9.89; S, 3.41. Found; C, 28.76; H, 3.35; N, 7.68; P, 9.81; S, 3.32.

The spectral properties of bio-dUTP and bio-UTP at pH 7.5 [λ max, 289 nm (ε = 7,100); λ max, 240 nm (ε = 10,700); λ min, 262 nm (ε = 4,300)] reflect the presence of an exocyclic double-bond in conjugation with the pyrimidine ring. These nucleotides also give a strong positive reaction (an orange-red color) when treated with p-dimethylaminocinnamaldehyde in ethanolic sulfuric acid, a procedure used for biotin quantitation (D.B. McCormick and J.A. Roth, Anal. Biochem., 34, 326, 1970). However, they no longer react

with ninhydrin, a characteristic reaction of the AA-dUTP and AA-UTP starting materials.

5

Examples 3 and 4

10

Synthesis of biotinyl-CTP and biotinyl-dCTP

CTP and dCTP were a) mercurated, b) reacted with allylamine, and c) biotinized with NHS-biotin, essentially as described in Example 1. CTP (56.3 mg, 0.1 mmole) or dCTP (59.1 mg, 0.1 mmole) were dissolved in 20 ml of 0.1 M sodium acetate buffer at pH 5.0, and mercuric acetate (0.159 gm 0.5 mmoles) added. The solution was heated at 50°C for 4.5 hours then cooled on ice. Lithium chloride (39.2 mg, 0.9 mmoles) was added and the solution extracted 6 times with ethyl acetate. The nucleotide products in the aqueous layer were precipitated by the addition of three volumes of cold ethanol and the precipitate collected by centrifugation. The precipitate was washed with absolute ethanol, ethyl ether, and then air dried. These products were used without further purification for the synthesis for AA-CTP and AA-dCTP, respectively. The mercurated nucleotides were dissolved in 0.1 M sodium acetate buffer at pH 5.0 and adjusted to a concentration of 10 mM (92 OD/ml at 275 nm). 0.6 ml (1.2 mmole) of a 2.0 M allylamine acetate stock (prepared as described in Example 1) was added to 10 ml of nucleotide solution (0.1 mmole) followed by the addition of K_2PdCl_4 (32.6 mg, 0.1 mmole), dissolved in 1.0 ml of H_2O . After standing at room temperature for 24 hours, the solution was filtered through a 0.45 μ m membrane to remove metal precipitates. The filtrate was diluted five-fold and loaded onto a 50 ml column of DEAE-sephadex A-25, preequilibrated with 50 mM TEAB at pH 7.5. The nucleotide prod-

35

ucts were fractionated by application of a 500 ml linear gradient (0.05-0.6 M) of TEAB at pH 7.5. The desired product was in the major UV absorbing portion which eluted between 0.28 and 0.33 M salt. The pooled samples
5 were desalted by rotary evaporation, dissolved in 0.5 M triethylammonium acetate at pH 4.2, and final purification achieved by HPLC chromatography on columns of Partisil ODS-2, using 0.5 M triethylammonium acetate as the eluent. Appropriate fractions were pooled, lyophilized, and the
10 products dissolved in H₂O. The nucleotides were converted to the Na⁺ salt by stirring briefly in the presence of Dowex TM 50 (Na⁺ form). After filtration, to remove the Dowex resin, the nucleotides were precipitated by the addition of 3 volumes of cold ethanol. The precipitate was
15 washed with ether and then air dried. Analytical results: AA-dCTP (C₁₂ H₁₇ N₄ O₁₃ P₃ Na₄ · 2H₂O); Theory, C, 22.29; H, 2.63; N, 3.67; P, 14.40. Found C, 22.16; H, 2.89; N, 8.77; P, 14.18. AA-CTP (C₁₂ H₁₇ N₄ O₁₄ Na₄ · 2H₂O); Theory C, 21.75; H, 2.57; N, 8.46; P, 14.01. Found, C, 22.03;
20 H, 2.47; N, 8.69; P, 13.81; Spectral properties in 0.1 M Borate buffer at pH 8.0, λ max 301 nm (ε =6,400), λ min 271nm (ε =3,950) λ max 250 nm (ε =9,700). Both AA-dCTP and AA-CTP give a positive ninhydrin test. AA-CTP (6.6 mg, 0.01 mmole) or AA-dCTP (6.4 mg, 0.01 mmole)
25 was dissolved in 5 ml of 0.1 M sodium borate buffer at pH 8.5, and NHS-biotin (3.4 mg, 0.01 mmole), dissolved in 0.2 ml of dimethylformamide, was added. After sitting at room temperature for 4 hours the sample was chromatographed on a 10 ml column of DEAE-Sephadex A-25, using a
30 150 ml linear gradient (0.1-0.9 M) of TEAB at pH 7.5, as eluent. Fractions containing biotinyl-CTP or biotinyl-dCTP, which eluted between 0.50 and 0.60 M TEAB, were pooled, desalted by rotary evaporation, and after being adjusted to a final concentration of 5 mM in 0.02 M Tris-
35 HCl buffer at pH 7.5, were frozen at -20°C. The products give a strong positive reaction for biotin with p-dimethylaminocinnamaldehyde in ethanol: sulfuric acid but give

a negative test for primary amines when sprayed with ninhydrin. Further structural characterization of these products is in progress.

5

Examples 5 and 6

10

Synthesis of Iminobiotinyl-UTP and Iminobiotinyl-dUTP

Iminobiotin hydrobromide was prepared from biotin as described previously (K. Hofmann, D.B. Melville and V. du Vigneaud, J. Biol. Chem., 141, 207-211, 1941; K. Hofmann and A.E. Axelrod, Ibid., 187, 29-33, 1950). The N-hydroxysuccinimide (NHS) ester of iminobiotin was prepared using the protocol previously described for the synthesis of NHS-Biotin (H. Heitzmann and F.M. Richards, Proc. Nat. Acad. Sci. USA, 71, 5537, 1974). AA-UTP (7.0 mg, 20 0.01 mmole) or AA-dUTP (6.3 mg, 0.01 mmole), prepared as detailed in example 1 (part b), was dissolved in 5 ml of 0.1 M sodium borate buffer at pH 8.5, and NHS-iminobiotin (3.5 mg, 0.01 mmole), dissolved in 0.5 ml of dimethylformamide, was added. The reaction mixture was left at 25 room temperature for 12 hours and then loaded directly onto a 10 ml column of DEAE-Sephadex A-25, preequilibrated with 0.05 M TEAB at pH 7.5. The column was eluted with a 150 ml linear gradient (0.05-0.6 M) of TEAB. Fractions containing iminobiotin-UTP or iminobiotin-dUTP, 30 which eluted between 0.35 and 0.40 M TEAB, were desalted by rotary evaporation in the presence of methanol and dissolved in H₂O. The products contained a small amount of allylamine-nucleotide adduct as an impurity, as judged by a weak positive result in the ninhydrin test. Final 35 purification was achieved by affinity chromatography on avidin-sepharose. Fractions of the impure product, made 0.1 M in sodium borate buffer at pH 8.5, were applied to

a 5 ml column of avidin-sepharose and washed with 25 ml of the same buffer. The column was then washed with 50 mM ammonium acetate buffer at pH 4.0, which eluted the desired iminobiotin-nucleotide product in a sharp peak.

5 The nucleotide was precipitated by the addition of 3 volumes of cold ethanol, washed with ethylether, dried in vacuo over sodium hydroxide pellets and stored in a desiccator at -20°C . Products were characterized by elemental analysis, as well as by spectral and chromatographic

10 ic properties.

15

Examples 7 and 8

Synthesis of NAGE-UTP and NAGE-dUTP

Allyl (3-amino-2-hydroxy-)propyl ether, abbreviated NAGE,

20 was prepared from allyl glycidyl ether (Age) (obtained from Aldrich Chemical Co.). 10 ml of Age (84 mmole) was added slowly (in a fume hood) to 50 ml of 9 M ammonium hydroxide and the mixture allowed to stand at room temperature for six hours. Excess ammonia was removed by

25 rotary evaporation under reduced pressure to yield a viscous yellow oil. Analysis of this product by proton NMR showed that it possessed the required structure. 5-mercuri-dUTP (0.1 mmole) or 5-mercuri-UTP (0.2 mmole) was dissolved in 2-4 ml of 0.2 M sodium acetate buffer at pH

30 5.0, and a 16 fold molar excess of NAGE adjusted to pH 5.0 with acetic acid prior to use, was added. The final reaction volumes (4.3 and 8.4 ml) had nucleotide concentrations of 43 and 42 mM, respectively. One equivalent of K_2PdCl_4 (0.1 or 0.2 mmoles) was added to initiate the

35 reaction. After standing at room temperature for 18 hours, the reaction mixtures were filtered through 0.45 μm membranes the samples diluted five-fold, and chroma-

tographed on columns of DEAE-Sephadex A-25, using linear gradients (0.1-0.6 M) of sodium acetate. Fractions containing the desired products, as judged by their UV spectra and characteristic HPLC elution profiles on Partisil ODS-2, were pooled, diluted, and further purified by rechromatography on DEAE-Sephadex using shallow gradients (0.1-0.5 M) of ammonium bicarbonate at pH 8.5. Under these conditions the majority of the NAGE-dUTP (or NAGE-UTP) could be cleanly separated from residual impurities. Proton NMR spectra were obtained at this stage of purification after the nucleotides were lyophilized and redissolved in D₂O. For elemental analysis, the products were converted to their sodium salt form. Typical analytical results: NAGE-dUTP (C₁₅ H₂₂ N₃ O₁₆ P₃ Na₄ · 2 H₂O), Theory, C, 24.99; H, 3.63; N, 5.83; P, 12.88. Found, C, 25.39; H, 3.71; N, 5.63; P, 12.88.

20

Example 9

Uses of Labeled DNA Sequences

25 I, Karyotyping

(a) Select from a human gene library some 100 to 200 clones. Label them as described above, and for each clone locate its place or places of hybridization visually or with a low-light-level video system. For those clones which correspond to a unique sequence gene this determines the location of the cloned DNA on a particular human chromosome. Obtain several clones for each chromosome. Each of these labeled clones can be used to identify particular chromosomes. They can also be used in combination to identify each of the 46 chromosomes as being one of the 22 autosomal pairs or the X or the Y. By allowing one set of labeled clones to hybridize to the chromosomes and then adding a fluorescent stain to the label, the set

of clones and their locations can be visualized and will fluoresce with a particular color. A second set of labeled clones could then be used and reacted with a second fluorescent dye. The same process can be repeated a number of times. Thus one can, if desired, have several sets of fluorescent labels attached to the cellular DNA at different but specific locations on each of the chromosomes. These labels could be used for visual or computerized automatic karyotyping.

10

(b) For automatic karyotyping, one could use one set of clones to identify the approximate location of each of the 46 chromosomes by finding sets of spots corresponding to the number of labeling sites on each chromosome. Thus, it is possible by computer analysis of the digitized images to determine if the chromosomes are suitably spread for further analysis. If they are suitably spread, then one can use computer analysis to identify each of the individual chromosomes by the location and distribution of the labelled spots on each one.

By using the fact that the fluorescent spots can be placed at specific locations on each chromosome, one can carry out either manual or automatic karyotyping very much more effectively than without such labels.

II. Diagnosis of Genetic Disorders

By selecting the clones which bind specifically to a particular chromosome, such as number 23, it is possible to count the number of copies of the particular chromosome in a cell even if the chromosomes are not condensed at metaphase. Thus when fetal cells are obtained for prenatal diagnosis of trisomy 21, the diagnosis can be done even if the chromosomes are not condensed at metaphase. If necessary, two sets of labels can be used - one which would be specific for chromosome 23 and one for some other

chromosome. By measuring in each cell the ratio of the two labels, which might be of different colors, it is possible to identify the cells which show an abnormal number of chromosomes number 23. This procedure could be used either on slides with a low-light-level video system or in a flow cytometer system using laser excitation. It can be used to determine any abnormal chromosome number.

10 III. Microorganism Detection and Identification

The labeling of specific sequences of DNA as described above permits identification and counting of individual bacteria. In order to identify the individual bacteria to which a particular fragment of DNA hybridizes the sensitivity must be such that a single labelled structure can be detected. This can be done using a low-light-level video system and computer summation of images, or by using some other device for intensifying the light image. A flow system can also be used if the sensitivity can be made sufficiently grand. If one immobilized the bacteria on a slide their location could be found and the number of such fluorescent spots counted. This would provide a count of all of those bacteria which contain DNA which can hybridize with the specific clone utilized. If the clone is selected as being specific for a particular strain of bacteria, then one can count the number of organisms of that strain. In addition, any antibiotic resistance for which a particular gene has been identified could be characterized in a similar way using, as a probe, the DNA sequence which is contained in the antibiotic resistance gene. In addition, a probe could be used which is specific for a resistance plasmid containing one or more antibiotic resistance genes. In addition to individual bacteria, groups of bacterial cells of a particular strain can be detected and their number estimated if they are located in a small spot so that the total

fluorescence specific to the hybridized DNA in the spot can be measured. In this way the number of organisms containing a specific DNA sequence can be measured in a mixture of bacteria.

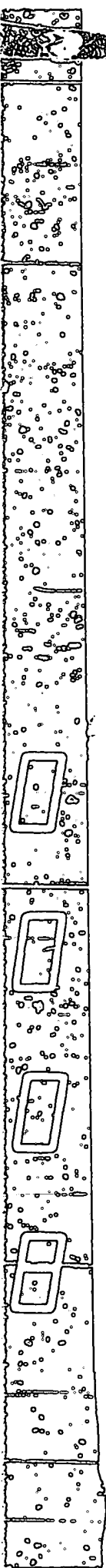

Claims

1. A compound having the structure:

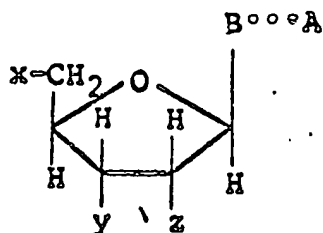

10 wherein B represents a purine, 7-deazapurine or pyrimidine moiety covalently bonded to the C^{1'} -position of the sugar moiety, provided that when B is purine or 7-deazapurine, it is attached at the N⁹-position of the purine or deazapurine, and when B is pyrimidine, it is attached at the N¹-position;

15 wherein A represents a moiety consisting of at least three carbon atoms which is capable of forming a detectable complex with a polypeptide when the compound is incorporated into a double-stranded ribonucleic acid, deoxyribonucleic acid duplex, or DNA-RNA hybrid;

20 wherein the dotted line represents a linkage or group joining B and A, provided that if B is purine, the linkage is attached to the 8-position of the purine, if B is 7-deazapurine, the linkage is attached to the 7-position of the deazapurine, and if B is pyrimidine, the linkage is attached to the 5-position of the pyrimidine; and

wherein each of x, y and z represents

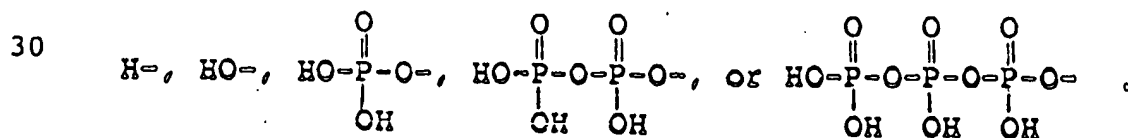

2. A compound having the structure:

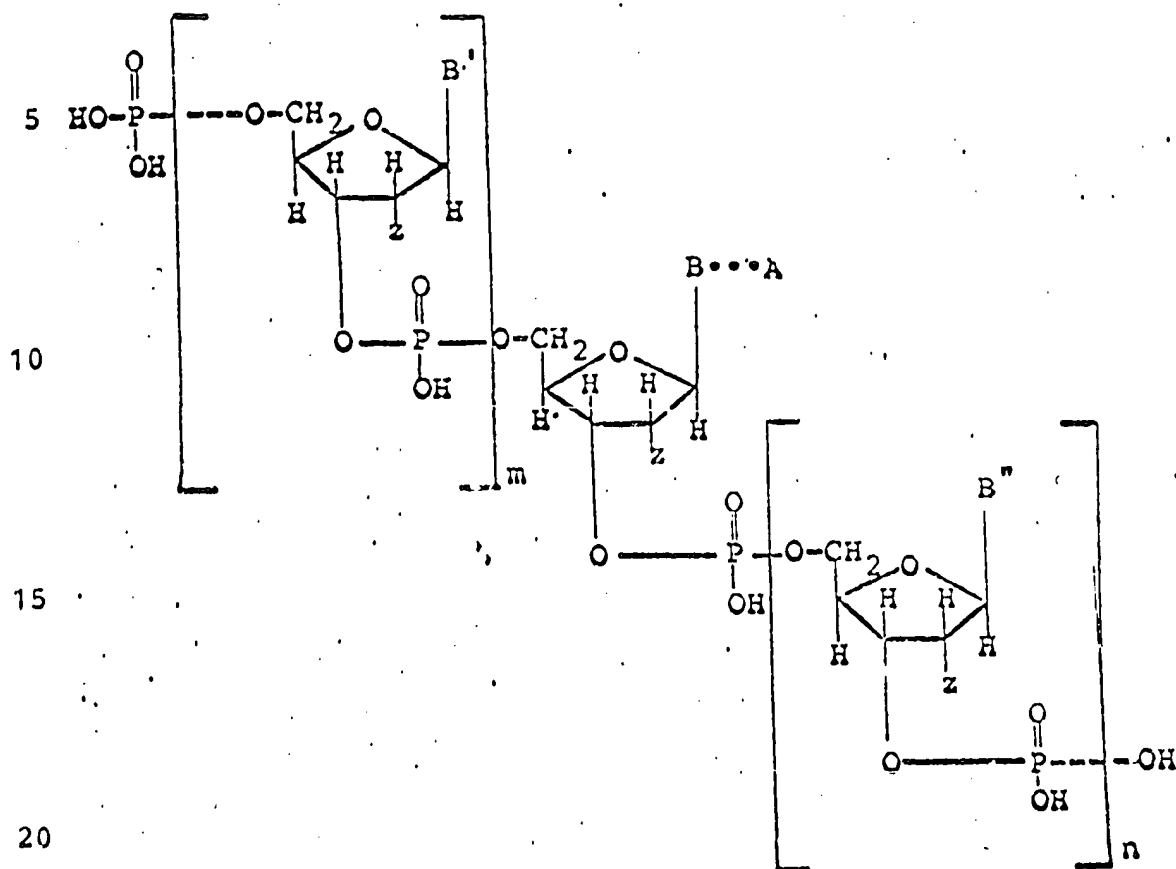

wherein each of B, B', and B'' represents a purine, deaza-
 purine, or pyrimidine moiety covalently bonded to the C^{1'}-
 25 position of the sugar moiety, provided that whenever B, B',
 or B'' is purine or deazapurine, it is attached at the N⁹-
 position of the purine or deazapurine, and whenever B,
 B', or B'' is pyrimidine, it is attached at the N¹-position;

30 wherein A represents a moiety consisting of at least
 three carbon atoms which is capable of forming a detec-
 table complex with a polypeptide when the compound is
 incorporated into a double-stranded duplex formed with a
 complementary ribonucleic or deoxyribonucleic acid mole-
 35 cule.

wherein the dotted line represents a chemical linkage
 or group joining B and A, provided that if B is purino, the

linkage is attached to the 8-position of the purine, if B is 7-deazapurine, the linkage is attached to the 7-position of the deazapurine, and if B is pyrimidine, the linkage is attached to the 5-position of the pyrimidine;

5

wherein z represents H- or HO-; and

wherein m and n represent integers from 0 up to about 100,000.

10

3. A compound in accordance with Claim 1 or 2 wherein A is a hapten.

15

4. A compound in accordance with Claim 1 or 2 wherein A is a ligand.

5. A compound in accordance with Claim 1 or 2 wherein A is biotin.

20

6. A compound in accordance with Claim 1 or 2 wherein A is iminobiotin.

25

7. A compound in accordance with Claim 1 wherein A is an organic moiety containing at least five carbon atoms.

8. A compound in accordance with Claim 1 wherein A is a non-aromatic organic moiety.

30

9. A compound in accordance with Claim 1 or 2 wherein the chemical linkage represented by the dotted line includes an olefinic bond at the α -position relative to B.

35

10. A compound in accordance with Claim 1 or 2 wherein the chemical linkage includes the moiety $-\text{CH}_2\text{-NH}-$.

11. A compound in accordance with Claim 9 wherein the olefinic chemical linkage is $-\text{CH}=\text{CH}-\text{CH}_2\text{-NH}-$.

12. A compound in accordance with Claim 9 wherein the olefinic chemical linkage is $-\text{CH}=\text{CH}-\text{CH}_2-\text{O}-\text{CH}_2-\underset{\text{OH}}{\text{CH}}-\text{CH}_2-\text{NH}-$.

5 13. A compound in accordance with Claim 1 wherein the chemical linkage is selected from or includes a moiety selected from the group consisting of

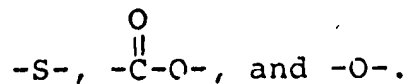

10

14. A compound in accordance with Claim 1 wherein B is uracil, cytosine, deazaadenine, or deazaguanine.

15. A compound in accordance with Claim 1 wherein x is

15

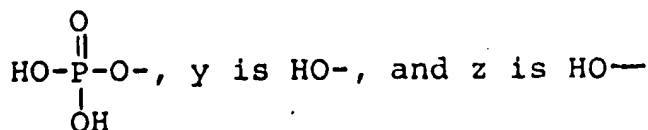

16. A compound in accordance with Claim 1 wherein x is

20

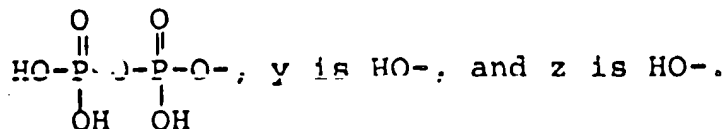

17. A compound in accordance with Claim 1 wherein x is

25

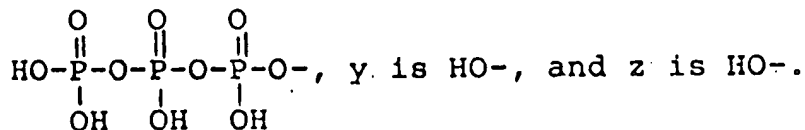

18. A compound in accordance with Claim 1 wherein x is

30

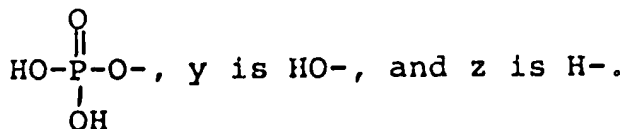

19. A compound in accordance with Claim 1 wherein x is

35

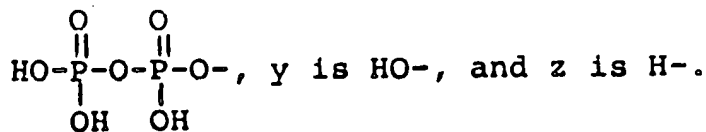

20. A compound in accordance with Claim 1 wherein x is

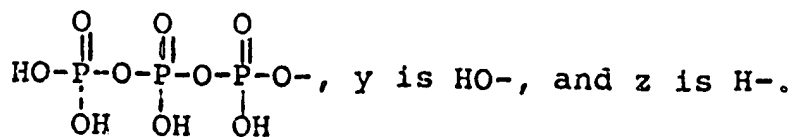

5

21. A compound in accordance with Claim 1 wherein x is

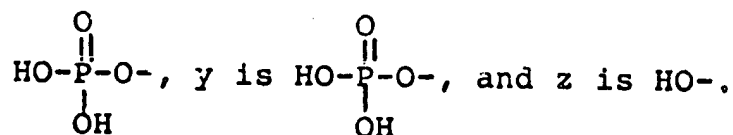

10

22. A compound in accordance with Claim 1 wherein x is

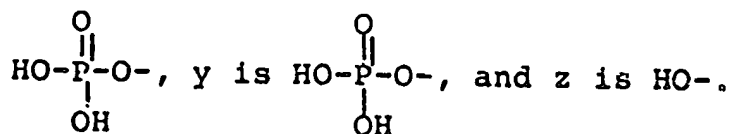

15

23. A compound in accordance with any of Claims 15 to 22, wherein A is biotin.

24. A compound in accordance with any of Claims 15 to 22 wherein A is iminobiotin.

25. A compound in accordance with any of Claims 15 to 24 wherein the chemical linkage is -CH=CH-CH₂-NH-.

26. A compound in accordance with any of Claims 15 to 24 wherein the chemical linkage is

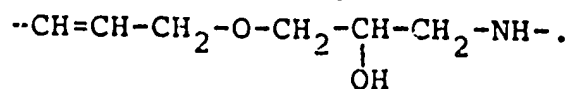

27. A compound in accordance with Claim 2 wherein m and n are not simultaneously 0.

28. A compound in accordance with Claim 2 wherein B is uracil, cytosine, deazaadenine, or deazaguanine.

29. A method of preparing a modified nucleotide having the structure:

5

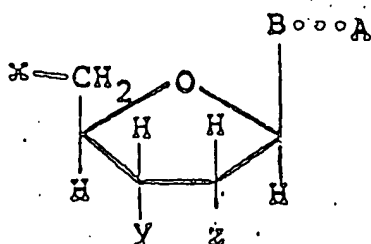

wherein B represents a purine, 7-deazapurine or pyrimidine moiety covalently bonded to the C^{1'}-position of the sugar moiety, provided that when B is purine or 7-deazapurine, it is attached at the N⁹-position of the purine or deazapurine, and when B is pyrimidine, it is attached at the N¹-position;

15 wherein A represents a moiety consisting of at least three carbon atoms which is capable of forming a detectable complex with a polypeptide when the compound is incorporated into a double-stranded ribonucleic acid, deoxyribonucleic acid duplex, DNA-RNA hybrid;

20

wherein the dotted line represents a chemical linkage joining B and A, provided that if B is purine, the linkage is attached to the 8-position of the purine, if B is 7-deazapurine, the linkage is attached to the 7-position of the deazapurine, and if B is pyrimidine, the linkage is attached to the 5-position of the pyrimidine; and

wherein each of x, y, and z represents

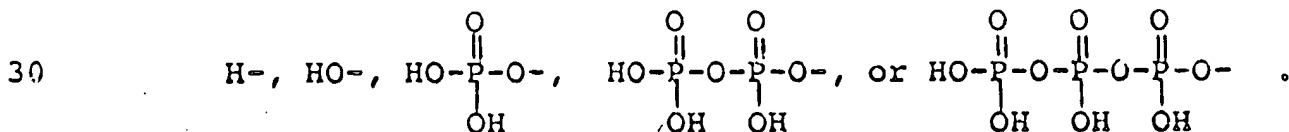

comprising the steps of:

(a) reacting a compound having the structure:

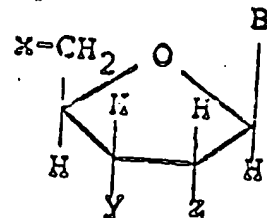

5

with a mercuric salt in a suitable solvent under suitable conditions so as to form a mercurated compound having the structure:

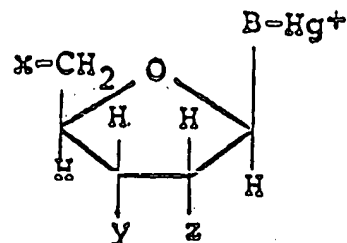

10

(b) reacting said mercurated compound with a chemical moiety reactive with the $-Hg^+$ portion of said mercurated compound and represented by the formula $\cdots N$, said reaction being carried out in an aqueous solvent and in the presence of K_2PdCl_4 under suitable conditions so as to form a compound having the structure:

20

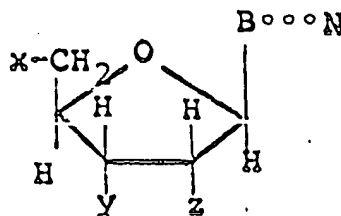

wherein N is a reactive terminal functional group or is A; and

25

(c) recovering said compound as said modified nucleotide when N is A, or when N is a reactive terminal group, reacting said compound with a compound having the structure M-A, wherein M represents a functional group reactive with N in an aqueous solvent under suitable conditions so as to form said modified nucleotide which is then recovered.

30
35

30. A method in accordance with Claim 25 wherein said chemical moiety represented by the formula ...N is

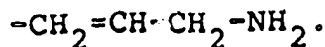

5 31. A method in accordance with Claim 25 wherein said chemical moiety represented by the formula ...N is

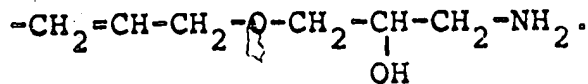

10 32. A method of making a compound in accordance with Claim 2 comprising an enzymatically polymerization of nucleotide triphosphates having the structure

15

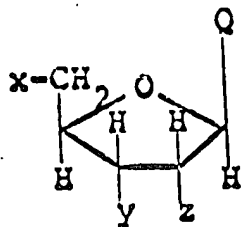

wherein Q represents B...A, B', or B'', and one of x and y represents

20

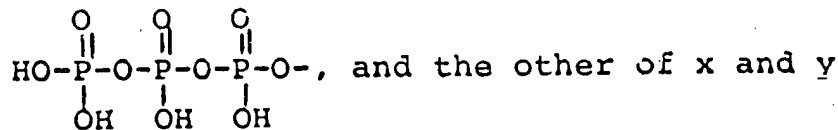

represents HO- in the presence of a nucleic acid template under suitable conditions so as to form said compound.
25

33. A method of making a compound in accordance with Claim 2 comprising the steps of:

(a) reacting a compound having the structure:

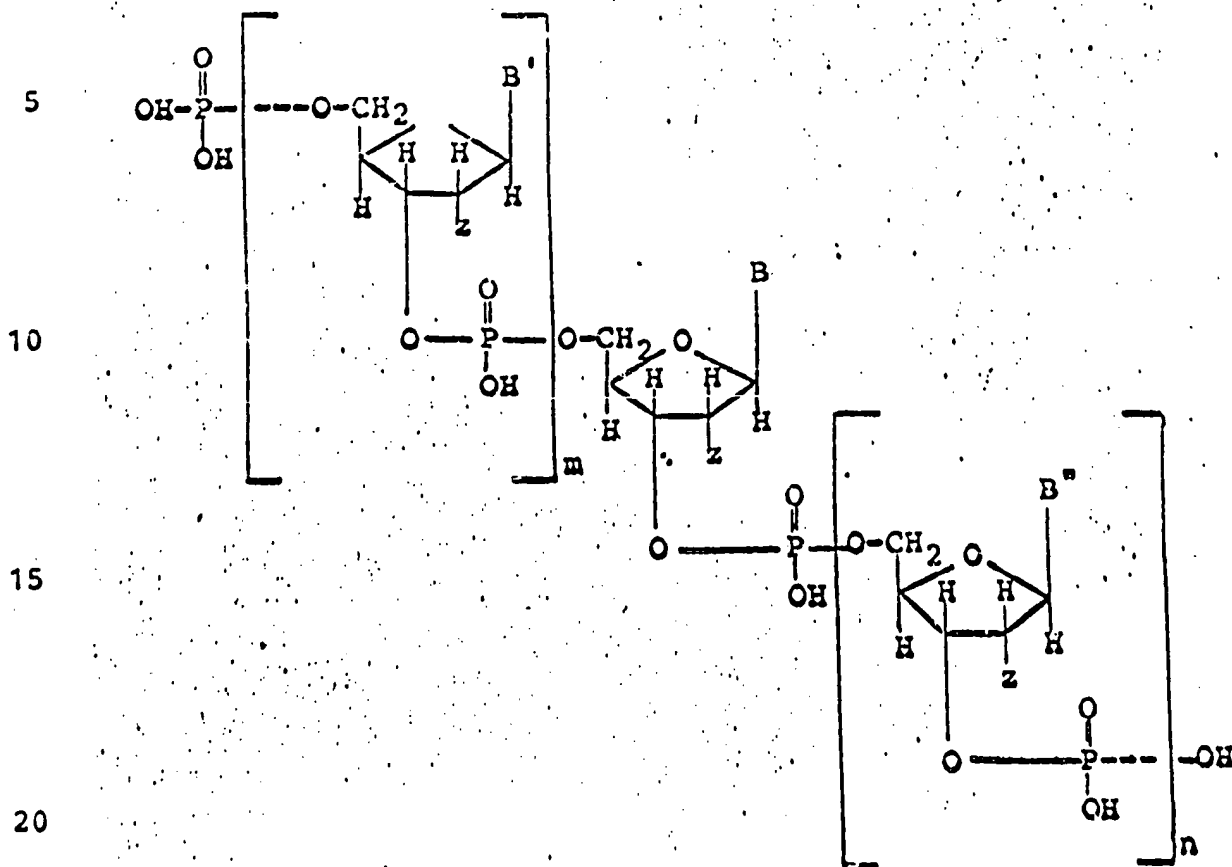

with a mercuric salt in a suitable solvent under suitable conditions so as to form a mercurated derivative compound having the structure:

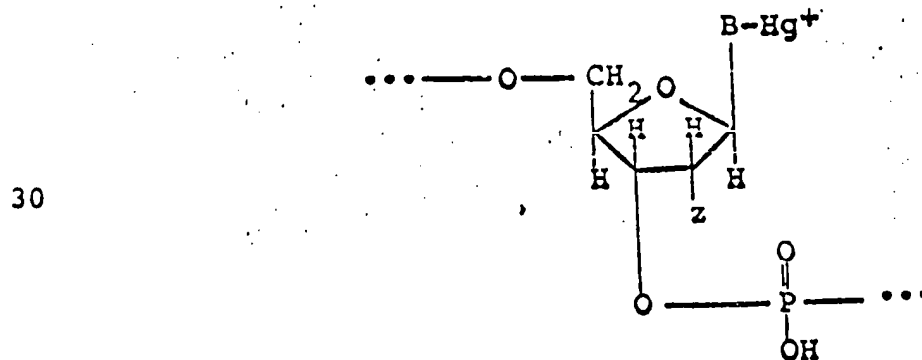

(b) reacting said mercurated derivative compound with a chemical moiety reactive with the $-Hg^+$ portion of said mercurated compound and represented by the formula $\cdots N$, said reaction being

35

carried out in an aqueous solvent and in the presence of K_2PdCl_4 under suitable conditions so as to form a compound having the structure:

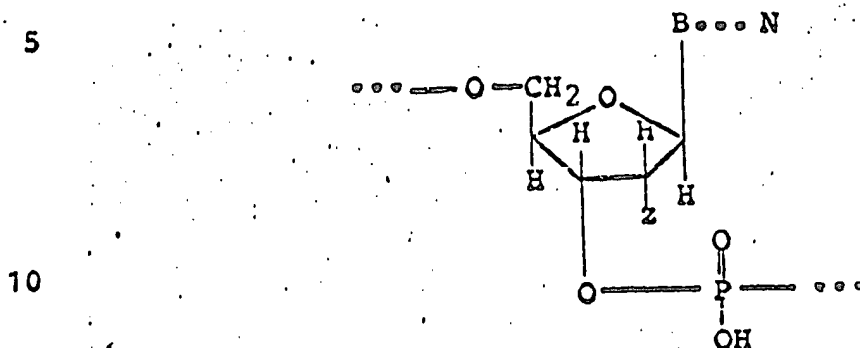

wherein N is a reactive terminal functional group or is A; and

15

(c) recovering said compound of Claim 2 when N is A, or when N is a reactive terminal group, reacting said compound with a compound having the structure M-A wherein M represents a functional group reactive with N in an aqueous solvent under

20

suitable conditions so as to form said compound of Claim 2 which is then recovered.

34. A method in accordance with Claim 33 wherein ...N

25

comprises thiol, carboxylic acid, epoxide, and amine.

35. A method in accordance with Claim 33 wherein said chemical moiety represented by the formula ...N is

30

$$-CH=CH-CH_2-NH-biotin.$$

36. A method in accordance with Claim 33 wherein said chemical moiety represented by the formula ...N is

35

$$-CH=CH-CH_2-O-CH_2-\underset{\substack{| \\ OH}}{CH}-CH_2-NH-biotin.$$

37. A method in accordance with Claim 33 wherein said chemical moiety represented by the formula ...N is

$$-CH=CH-CH_2-NH-iminobiotin.$$

38. A method in accordance with Claim 33 wherein said chemical moiety represented by the formula ...N is

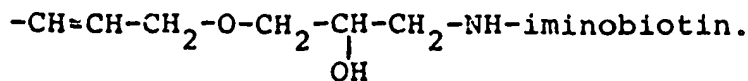

5

39. A method of detecting a compound in accordance with Claim 1 which comprises contacting said compound with a polypeptide capable of forming a complex therewith under suitable conditions so as to form said complex, said

10 polypeptide being capable of or including a moiety which can be detected when said complex of said compound and said polypeptide is formed, and detecting said complex using an appropriate detection technique.

15 40. A chemical complex comprising a compound in accordance with Claim 1 and a polypeptide capable of forming said complex with said compound.

20 41. A method of detecting a compound in accordance with Claim 2 which comprises contacting said compound with a polypeptide capable of forming a complex therewith under suitable conditions so as to form said complex, said polypeptide including a moiety which can be detected when
25 said complex of said compound and said polypeptide is formed, and detecting said complex using an appropriate detection technique.

30 42. A chemical complex comprising a compound in accordance with Claim 2 and a polypeptide capable of forming said complex with said compound.

35 43. A chemical complex in accordance with Claim 42 wherein said polypeptide includes a moiety which can be detected, being a fluorescent dye, electron dense reagent, or enzyme capable of depositing an insoluble reaction product.

44. A method of detecting a double-stranded polynucleo-

- 5 so as to form said complex, said polypeptide including a moiety which can be detected when said complex of said polynucleotide duplex and said polypeptide is formed, and detecting said complex.
- 10 45. A double-stranded polynucleotide duplex which includes a compound in accordance with either Claim 1 or Claim 2.
- 15 46. A method of determining the presence of a deoxyribonucleic or ribonucleic acid molecule which comprises forming a double-stranded hybrid polynucleotide duplex which includes a single strand of deoxyribonucleic or ribonucleic acid corresponding to or derived from said deoxyribonucleic or ribonucleic acid molecule and a compound in accordance with Claim 2, and detecting said double-stranded hybrid polynucleotide duplex according to the method of Claim 44.
- 20 47. A method of diagnosing the presence of a nucleic acid-containing etiological agent in a subject which comprises obtaining a suitable sample from said subject, determining the presence in said sample of deoxyribonucleic or ribonucleic acid naturally associated with said etiological agent by forming a double-stranded polynucleotide duplex which includes a compound in accordance with Claim 2 and a single strand of deoxyribonucleic or ribonucleic acid corresponding to or derived from said deoxyribonucleic or ribonucleic acid which is naturally associated with said etiological agent under suitable conditions, and detecting the presence of said double-stranded polynucleotide duplex using the method of Claim 44.
- 25 48. A method of testing a bacterium to determine the
- 30
- 35

presence of resistance to an antibiotic which comprises preparing a polynucleotide complementary to the deoxyribonucleic acid gene sequence of said bacterium which confers resistance to said antibiotic and includes the compound of Claim 1 incorporated therein, contacting
5 said polynucleotide with deoxyribonucleic acid obtained from said bacterium under suitable conditions so as to form a double-stranded hybrid duplex, contacting said duplex with a polypeptide capable of forming a complex
10 with said hybrid duplex under suitable conditions, said polypeptide including a moiety which can be detected if said complex is formed, and detecting the presence of said complex using an appropriate detection technique, the presence of said complex indicating resistance to
15 said antibiotic and the absence of said complex indicating susceptibility to said antibiotic.

49. A method of diagnosing a genetic disorder in a subject which comprises preparing a polynucleotide complementary to the deoxyribonucleic acid gene sequence of said
20 subject which is associated with said genetic disorder and includes the compound of Claim 1 incorporated therein, contacting said polynucleotide with deoxyribonucleic acid obtained from said subject under suitable conditions so as
25 to form a double-stranded hybrid duplex, contacting said duplex with a polypeptide capable of forming a complex with said hybrid duplex, said polypeptide including a moiety which can be detected when said complex is formed, and detecting the presence of said complex using an
30 appropriate detection technique, the presence or absence of said complex indicating the presence or absence of said genetic disorder.

50. A method of diagnosing thalassemia in a human subject which comprises preparing a polynucleotide complementary to the deoxyribonucleic acid gene sequence which is
35 absent in β -minus thalassemic subjects and includes the compound of Claim 1 incorporated therein, contacting said

polynucleotide with deoxyribonucleic acid obtained from said subject under suitable conditions so as to form a double-stranded hybrid duplex, contacting said duplex with a polypeptide capable of forming a complex with
5 said hybrid duplex under suitable conditions, said polypeptide including a moiety which can be detected when said complex is formed, and detecting the presence of said complex using an appropriate detection technique, the absence of said complex indicating the presence of β -
10 minus thalassemia.

51. A method of chromosomal karyotyping which comprises preparing a series of modified polynucleotides corresponding to a series of defined genetic sequences located
15 on chromosomes, said polynucleotides including compounds in accordance with Claim 1, contacting said polynucleotides with deoxyriboxyribonucleic acid obtained from chromosomes so as to form hybrid duplexes, contacting each of said duplexes with a polypeptide which is capable of
20 forming a complex with each such duplex, said polypeptides including moieties which can be detected when said complexes are formed, and determining the location of each complex on said chromosomes so as to thereby determine the location of said genetic sequences on said chromosomes.
25

52. A method of detecting a polynucleotide which includes the terminal polynucleotide sequence poly A which comprises preparing a modified poly U molecule in which
30 at least one uracil moiety has been modified by chemical addition at the 5-position of a moiety A consisting of at least three carbon atoms which is capable of forming a detectable complex with a polypeptide when the modified uracil moiety is incorporated into a double-stranded poly A-poly U duplex, forming such a poly A-poly U duplex
35 by contacting said polynucleotide containing said poly A sequence with said modified poly U molecule under suitable conditions, and detecting resulting duplexes so as to

thereby detect said polynucleotide.

53. A method of tumor or cancer cell identification which comprises detecting malignant cells by detecting abnormal hormonal receptor sites associated therewith by providing:

(1) a compound in accordance with Claim 1 in which x or z is H- or HO- and the other two of x, y and z are reacted to form the cyclic moiety.

10

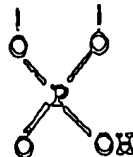

15

(2) and binding said compound to the said sites under suitable conditions permitting binding, disrupting said cells to produce cell surface fragments to which said compound is bound, separately recovering said cell surface fragment, and identifying the same so as to identify said hormone receptor sites.

20 54. A method of diagnosing a tumor cell which comprises preparing a polynucleotide which is complementary to a messenger ribonucleic acid synthesized from a deoxyribonucleic acid gene sequence associated with production of a polypeptide diagnostic for said tumor cell and includes a
25 compound in accordance with Claim 1, introducing said polynucleotide into said cell under suitable conditions so as to permit said polynucleotide to hybridize with said deoxyribonucleic acid gene sequence, and determining whether said polynucleotide hybridizes.

30

55. A diagnostic kit useful for determining the presence of a nucleic acid - containing organism such as a bacterium which comprises a compound in accordance with Claim 2 which is complementary to all or a unique portion of the
35 nucleic acid contained in said organism and a polypeptide capable of forming a detectable complex therewith.